

Components Approved as Compatible

The following list contains the only components approved as compatible for use in the DHT system. This version is current at the time it was downloaded. The most current versions will be posted on the Strong Enterprises website: www.strongparachutes.com.

Part Number	Description
114702	Instructor Harness and Container
990064	Cypres Tandem AAD 2-pin
990092	Vigil Tandem AAD 2-pin
780630	RSL
627264	Reserve Ripcord
862030	Cutaway Handle
678410	Main Drogue Release Handle(s)
861515	Drogue Riser Through loop
861517	Main Closing Loop
861017	Reserve Closing Loop
861035	Hesitater Loop
570500, n/a	Packing Data Card (any style but must remain with reserve canopy throughout life)
Various	Strong Enterprises Student Harness
430083	Patronus Reserve Canopy - w/ Patronus Free bag 730327 only
430085	Master Reserve - w/ Master reserve Free bag 730324 only
866061	Reserve Toggles
730324	Master reserve free bag with bridle
730327	Patronus reserve free bag with bridle
790130	Grabber Pilot Chute (TNT)
Various	SET series Main Canopies
n/a	Aerodyne A-2 Tandem Canopy (only with Strong Enterprises Risers)
n/a	Icarus Tandem Canopy (only with Strong Enterprises Risers)
n/a	Firebolt Tandem Canopy (only with Strong Enterprises Risers)
410064	Master Main Canopy
410078	T-520 Main Canopy
834608	Main Risers
866071	Main Toggles (single toggles)
866072	Main Flare Toggles (dual toggles, recommended for T-520 and Master Main)
720532	Main Deployment Bag with Velcro
720534	Main Deployment Bag Sewn Shut
480026	Drogue with Solid Bridle
813016	Y Style Deflation Line



Owner's Manual
For packing and maintenance of

Dual Hawk Tandem System

with

SET-400 & SET-366 Main Canopies

Part number: 411540 & 411366

and

Master Reserve Canopy

Part number: 430085



Strong Enterprises

"The parachute company with imagination"

Division of S.E. Inc.

11236 Satellite Blvd. Orlando, FL 32837

Tel. (407) 859-9317 Fax: (407) 850-6978

www.strongparachutes.com sales@strongparachutes.com

! WARNING !

Parachuting is a hazardous activity that can result in serious injury or death. Failure to follow all warnings, instructions and required procedures may result in serious injury or death. Parachutes sometimes malfunction even when they are properly designed, built, assembled, packed, maintained and used. The results of such malfunctions are sometimes serious injury or death. There are so many factors, both human and natural beyond our control, that we want you to clearly understand that by using or intending to use our equipment, you are assuming a considerable risk of personal injury or death. If you are not willing to assume that risk, please return the equipment to the dealer where it was purchased for a full refund.

DISCLAIMER

There are NO WARRANTIES that extend beyond the description of the products in this manual and neither the seller nor any agent of the seller has made any affirmation of the fact or promise with respect to the products except those that appear therein.

The liability of the seller is limited to the duty to replace defective parts found upon examination by the manufacturer to be defective in material or workmanship within 7 days after purchase and found not to have been caused by any accident, improper use, alteration, tampering, abuse or lack of care on the part of the purchaser.

This is a high performance parachute system and must be packed in accordance with the instructions in this manual.

Any person using this equipment must have successfully completed a Strong Enterprises Certification Course (TICC). The correct use of this equipment shall be the responsibility of the Strong Enterprises Certified Tandem Instructor.

Congratulations on the Purchase of your NEW Dual Hawk Tandem System

This Manual is organized into five separate sections.

Section One contains the general information concerning your new DHT system.

Section Two contains Instructor information.

Section Three contains the inspection and maintenance requirements.

Section Four contains the rigging procedures.

Section Five contains the Appendices.

Each section contains valuable information concerning this DHT system and it is required that you read all sections completely prior to use. In addition all persons must successfully complete a Strong Enterprises Tandem Instructor Certification Course (TICC) before using this equipment.

All Tandem jumps made on the DHT System must be completed in accordance with the rules of the country in which the jump is performed (in the US: FAA FAR 105.45), this operation manual, and the Strong Enterprises Training Syllabus for the Tandem Instructor Certification Course (TICC). Any violation of these procedures will cause revocation of privileges.



Table of Contents

Warning/Disclaimer

Table of Contents4

Section 1 1-1

- 1.0 Introduction to Tandem Skydiving 1-2
- 1.1 Scope 1-2
- 1.2 Operational Limitations 1-2
- 1.3 Parachute Repack Interval..... 1-3
- 1.4 System Description 1-3
- 1.5 Reporting of Equipment Improvement Recommendations..... 1-8

Section 22-1

- 2.0 Introduction2-1
- 2.1 System Function2-2
- 2.2 Harness Fitting2-4
- 2.3 Operator Pre-Jump Inspection.....2-8

Section 33-1

- 3.0 Introduction3-2
- 3.1 Care of your Dual Hawk System.....3-2
- 3.2 System Service Life.....3-2
- 3.3 Inspections and Maintenance.....3-2
- 3.4 Repair Guidelines.....3-7
- 3.5 Closing loop Construction.....3-9

Section 44-1

- 4.0 Introduction 4-2
- 4.1 Approved Components4-2
- 4.2 Packing Tools and Consumables4-3
- 4.3 Preparing the Reserve Container and Canopy4-4
- 4.4 Packing of the Master Reserve Canopy4-7
- 4.5 Closing the Reserve Container4-24
- 4.6 Preparing the Main Canopy4-33
- 4.7 Packing the Main Canopy.....4-36
- 4.8 Closing the Main Container4-45
- 4.9 Packing the Drogue.....4-50

Section 55-1

- Appendix A: Line Charts 5-2
- Appendix B: TSO Letter for Dual Hawk Tandem System.....5-11
- Appendix C: Dual Hawk Tandem Inspection Checklist5-12

Section One:

General Information



1.0 Introduction To Tandem Skydiving

The chronicle of tandem skydiving, like so many elements of our sport, began with the vision and enthusiasm of an experienced skydiver trying something new. More significantly, to share the thrill of freefall skydiving with someone else. It was 1977 and most parachutes in use were “rounds”. Parachute technology was evolving but still far behind today’s sophisticated equipment and procedures.

The skydiver took his wife as his first “Tandem Student,” strapping her into the same harness with him for the experiment. Encouraged by the relative success, other skydivers made more jumps.

In November 1982 intrigued by the possibilities of an actual training program centered on tandem skydiving, Ted Strong and Bill Morrissey began engineering the tandem concept into real equipment made specifically for tandem jumping.

The first tandem jump made on this newly engineered equipment was made in January 1983 with Ted Strong as the tandem pilot and Ricky Meadows, an employee at Strong Enterprises, the student.



During the next two and a half years hundreds of experimental tandem jumps were made. During this time the student ripcord, Master Reserve, and drogue systems were all incorporated into the design and resulted in tandem skydiving equipment and procedures reaching an acceptable level of feasibility and more importantly, safety. In 1987, US Patent #4,746,084 was issued to Strong Enterprises for this original and pioneering work on the major tandem concepts.

Commitment to development and innovation continues today. We at Strong Enterprises are constantly creating new and innovative products living up to the name “The parachute company with imagination”!

Today, almost one million tandem skydives are made each year, bringing the thrill of freefall skydiving to a vast and more diverse audience than ever before while giving the student a measure of safety not available during other teaching methods.

1.1 Scope

This DHT manual P/N 510045 is a component of the DHT system, it covers the manufacturer’s instructions for the assembly, operation, packing, maintenance and approved components of this Dual Hawk Tandem Parachute System.

1.2 Operational Limitations

The Strong Enterprises Dual Hawk Tandem System is specifically designed for two people with total loads of up to 500 lbs and opening speeds up to 175 knots IAS. The use of unapproved parts and components is prohibited.

1.3 Parachute Repack Interval

The Strong Enterprises Master Reserve Canopy has a 365-day repack cycle. Your countries laws may dictate a stricter schedule, check your local regulations. The reserve canopy must be packed by an FAA certificated parachute rigger with a back type rating, military equivalent, or foreign equivalent. Alternately it may be returned to Strong Enterprises or an authorized Recertification Center for complete inspection and repack. If your DHT system is exposed to moisture, excessive dirt or is damaged it should be inspected sooner than the maximum allowed. All records must be kept in accordance with regulations.

Note!

USA current repack regulations can be found in FAA FAR 105.43

1.4 System Description

The Strong Enterprises Dual Hawk Tandem Parachute System is designed for freefall and open canopy dual instruction applications. It allows two people, a Strong Enterprises Certified Tandem Instructor in the rear and a student in the front, to jump using one extra large main parachute while having the back up reliability of a compatible reserve parachute. The packed system, ready to jump, measures 26 inches long by 16 inches wide by 8 inches thick.

The complete assembly consists of the Dual Hawk Tandem instructor harness and container assembly, a student harness, the main deployment system, and the reserve deployment system.

All Tandem jumps made on the DHT System must be completed in accordance with FAA FAR 105.45 (or local regulations), this operation manual, and the Training Syllabus for the Tandem Instructor Certification Course (TICC). Any violation of these procedures will cause revocation of privileges.

1.4.1 Dual Hawk Main Harness/Container Description

1.4.1.1 Instructor Harness

The harness is made using type 7 webbing. The type 7 has a tensile strength of 6,000 lbs. It is integrated directly into the container. The harness has integrated reserve risers and drogue risers that ensure loads are evenly spread throughout. The harness is secured to the instructor by three adjustable attachment points; one chest strap and two leg straps. Additionally there are two lower adjustment points that allow users of all shapes and sizes a comfortable and secure fit.

The specially designed 3-D ring was pulled to 11,200 lbs with only a .002" distortion. Its unique design attaches the student harness directly to the main and reserve canopies which has multiple benefits. It allows independent loading of the instructor and student harnesses under the main or reserve canopy. This means that the Tandem Instructor can fly under the canopy unencumbered by the weight of the student. It also keeps the students weigh and g-forces from transferring to the instructor harness, instead it is transferred directly to the canopy via the 3-D ring. In addition, since it is a solid piece of hardware it isn't consistently stretching the main lift webbing, thus eliminating a wear point and extending the life of the harness.



1.4.1.2 Container

The container is made of 1,000 denier nylon Cordura and parafoam materials. The Cordura outside creates a rugged long lasting container that can take the abuse of years of jumping. The parafoam inside allows a cushioned smooth surface for the more delicate line and parachute materials. The container consists of three parts, the reserve pack tray, the main pack tray, and the backpack.



The reserve pack tray is equipped with all the pockets and channels to allow the installation of a two pin tandem AAD. The closing flap configuration allows for clean, quick reserve deployments. With only two flaps to clear, the pilot chute loses little to no momentum leaving the pack tray and is quickly in clean air extracting the reserve canopy. The guide rings on the top flap ensure that ripcord pins remain untangled, unbent, and allow a quick inspection of pins, RSL ring, and routing giving the instructor peace of mind knowing everything is in order. No complicated rigging to inspect! On the outside bottom of the reserve container there is a small hide-away pocket that can be used for spare closing loops and through loops.

The main pack tray is designed to hold canopies from 360 sq. ft. to 520 sq. ft. This is achieved through our innovative flap and two-loop configuration. The closing flaps fold neatly around the main deployment bag and the two loop closing ensures that even if the closing pin is worked loose from one loop the top and bottom flaps will secure the deployment bag until the instructor is ready to deploy the main canopy. The dura-stretch pouch on the outside bottom of the main pack tray ensures a secure and accessible position for the drogue. Covered channels along the outside of the main pack tray secure the drogue bridle preventing accidental and unwanted snags while allowing quick and easy deployment when the drogue is tossed during free fall.

1.4.1.3 Handles and RSL

The DHT has four handles each with a specific purpose.

There are two drogue release handles. The handles are a PVC grip with a 5/32 inch coated aircraft cable, 41 inches long. Both drogue release ripcords (primary and secondary) are located on the instructor's right main lift web. The primary main drogue release ripcord and ripcord cable housing is designed to be detached from the instructor's main lift web and attached to the student's harness as the student is being connected to the instructor. The primary drogue release is clipped to the student harness and is used to teach the student how to activate the main canopy. The primary drogue release is equipped with a bungee system that ensures the handle remains with the system and will not be lost or "thrown away". Both the primary and secondary drogue release handles perform the same job, by using a through loop system. Either the primary, secondary, or both can be used without affecting the function of the system. When pulled the drogue release lets the through loop release the drogue 3-ring and allows the drogue bridle to detach from the harness and pull the main deployment bag from the main pack tray.



The Cutaway handle is a soft Cordura “pillow” that attaches outboard on the instructor’s right main lift web and has two coated 3/32” stainless steel cables. The easy grip “finger pocket” handle allows a quick, no-slip pull. An additional safety feature of the cutaway handle is the addition of a drogue release loop. The instructor’s drogue release cable is placed through this loop ensuring that all three main canopy points (two main risers and one drogue riser) are released upon cutaway, eliminating the chance of a main/reserve entanglement. When pulled the cutaway handle releases both main riser three ring systems as well as the drogue three ring, allowing the instructor to completely remove him/herself from the malfunctioning canopy.



Attached to left side main riser is a Reserve Static Line (RSL) lanyard. Release of main canopy (cutaway) will pull RSL lanyard taunt. RSL lanyard terminates with a ring which is placed around the cables holding the reserve straight pins. Once RSL lanyard is tight it will pull the reserve pins opening the reserve container. This allows spring loaded pilot chute to be released. The RSL will most likely have the reserve container open before the parachutist has a chance to pull the reserve ripcord. This does not mean the parachutist can neglect to pull the reserve ripcord.



The reserve ripcord is an angled “D” (Raft) handle located outboard on the instructor’s left main lift web. The shorter cable is 25-1/4 inches while the longer cable is 26-1/2 inches. A locking ripcord pin terminates each cable. When pulled the reserve handle allows the reserve pack tray to open and releases the spring loaded pilot chute.



1.4.2 Tandem Student Harness Description

Similar to the main harness the student harness is made of type VII webbing throughout. The student harness is secured to the student by four fully adjustable attachment points; two leg straps, one chest strap, and one belly band. There are six additional adjustment points; one on each main lift webbing, one on each lower side, one across the small of the students back and the Y-mod strap. When properly fitted these adjustment points ensure the student is secure in the harness and will be comfortable during the skydive.



The student harness is secured to the main harness using two 5000-pound butterfly snaps for the upper attachment to the instructor harness, and two 2500-pound adjustable quick ejector snaps for the lower/side attachments. This heavy duty hardware ensures that the student remains secured to the instructor.

1.4.3 Main Deployment System

The main deployment system consists of the drogue and bridle, the main deployment bag, and the main canopy.

1.4.3.1 Drogue and Bridle

The drogue chute incorporates a hemispherical design with an open diameter of 3 feet. A deployment handle (drogue pud) is located at the apex. The drogue is designed to create enough drag to keep the tandem pair in a steady belly to earth free fall position while slowing the descent rate to 120 mph. This ensures a more stable free fall and keeps the tandem pair falling at approximately the same rate as an individual skydiver. As well as giving the student a more accurate representation of a solo skydive. The drogue is attached to the main canopy by a 13 ft bridle made of 1-1/2 inch Kevlar, with a deflation system that runs from the apex of the drogue canopy to the main canopy bridle attachment point. When either drogue release is pulled the drogue remains inflated pulling the main deployment bag and canopy fully from the pack tray. By keeping the drogue inflated throughout the process we avoid an exaggerated "trap door" effect and keep positive force from the drogue to the risers throughout deployments. The deflation line only collapses the drogue once the canopy is free of the deployment bag and opening. This works the same as a solo parachute system again giving the student the most realistic training possible. Once the main canopy begins to inflate the drogue is deflated to avoid unnecessary stress to the top of the main canopy while in flight and extends the life of both main canopy and drogue.



1.4.3.2 Main Deployment Bag

The ALS (Anti Line Slump) main deployment bag eliminates line slump (also known as line dump) on deployment while allowing the use of rubber bands to stow the lines. Once the drogue has pulled the ALS bag from the pack tray the ALS bag releases one line stow at a time keeping the lines under constant, uniform tension. This constant, uniform tension keeps the deployment symmetrical and helps to minimize malfunctions caused by line dump and lop-sided openings. The inner flap keeps the bag closed while the lines are deploying thus ensuring a properly sequenced deployment.



1.4.3.3 Main Canopy

The main canopy is constructed and tested to handle loads up to 500 lbs. Strong Enterprises offers four main tandem canopies; the Master Main, the T-520, the SET-400, and the SET-366. In addition tests have been conducted and proven other manufacturers main canopies to be compatible when used with Strong Enterprises risers and main deployment bags. For the complete list see the most current "Approved Components List" available on the website. All Strong Enterprises main canopies can be ordered with Spectra, HMA, or Vectran lines. The main steering toggles have three loop positions to allow instructor and student to each control the canopy without excessive stretching or reaching. For more technical information about Strong Enterprises main canopies please see the following chart.



Component	With SET400	With SET-366	With Master 425	With T520
System Weight, lbs	54	53	53-1/2	55-1/2
Span, ft	40	34.5	31-1/2	38-1/2
Chord, ft	12.6 to 10.4	11.8 to 9.7	13-1/2	13-1/2
Area, sq. ft.	402	360	425	520
Weight (less risers), lbs	15	14	14	16-1/2
Canopy Fabric	1.18 oz, 0 cfm	1.18 oz, 0 cfm	1.1 oz, 0-3 cfm	1.1 oz, 0-3 cfm
Slider Dimensions, in x in	34 x 34	34 x 34	33 x 33	33 x 36
Forward Speed (400 lbs), mph	30	30	26	20
Rate of Descent, fps	12-14	14-16	12-14	10-12
Max Suspended Weight, lbs	500	500	500	500

1.4.4 Reserve Deployment System

The reserve deployment system consists of a pilot chute and bridle, a reserve deployment bag, and a reserve canopy.

1.4.4.1 Reserve Pilot Chute

The Grabber Reserve Pilot Chute is a spring type, 36-inch diameter, high drag pilot chute made of ripstop nylon with a meshed lower portion. With 28 lbs of pressure the spring quickly launches the pilot chute into the air when released. The bridle consists of a 13-foot length of type XII nylon webbing. This gives the pilot chute enough distance to get clean air but not too much so as to slow deployment of the reserve.



1.4.4.2 Reserve Deployment Bag

The reserve deployment bag is a wedge shaped “free” type bag made from ripstop nylon with four grommets on the locking flap and four stows on each side. Similar to the ALS bag the freebag is extracted from the reserve pack tray and lines are uniformly and symmetrically released from the line stows. Finally the last stow is released and the pilot chute pulls the freebag off and away from the reserve canopy. The freebag and pilot chute are not attached to the canopy allowing the reserve canopy to perform its function without interference or additional stress.



1.4.4.3 Master Reserve Canopy

The Master Reserve is specifically designed to handle two people and loads up to 500 pounds. The canopy has nine cells and is 425 square feet. The fabric is 1.12 oz, 0-3 cfm ripstop nylon with 700 lb Kevlar cord for all lines. The Master Reserve is reinforced with Kevlar tapes as well to allow it to survive the worst scenarios imaginable. Once clear of the freebag the canopy inflates from center out.

1.5 Reporting of Equipment Improvement Recommendations

In our effort to continuously improve our products, processes, and services, we invite you to send us your comments. As a properly trained and qualified user of this equipment, you are uniquely suited to provide us with valuable feedback regarding design and/or performance. Tell us what you like as well as what you don't like. Send us an email or mail us a letter to:

Strong Enterprises
11236 Satellite Blvd.
Orlando, Florida 32837
tandem@strongparachutes.com
www.strongparachutes.com

Section Two:

Instructor Information



2.0 Introduction

The following information is provided as a general guideline and is not intended to be used as a Tandem Instructor Certification Course. All Tandem jumps made on the DHT System must be completed in accordance to FAA FARs (or foreign equivalent), this operation manual, and the Strong Enterprises Training Syllabus for the Tandem Instructor Certification Course (TICC). Any violation of these procedures will cause revocation of privileges.

2.1 System Function

2.1.1 Main Deployment

After exiting the aircraft the tandem pair will arch and get into a stable belly to earth position. The Instructor (or student during training) will then reach to the bottom of the main container and locate the drogue pud. They will then grab the drogue and toss the extracted drogue into the wind stream, thus setting the drogue.

When the Tandem pair reaches the deployment altitude the Instructor or Student will wave off and clear the air above them. They will then Look-Reach-Grasp one of the two main drogue release ripcord handles and pull releasing the drogue 3-ring. As the drogue 3-ring is released the drogue bridle is extracted. As bridle reaches full extension, it lifts the ALS bag out of container and line stows are released one by one, continuing extraction process. At full line extension the main canopy will be extracted from the ALS bag and released into wind stream. Each of the nine cells of the main canopy begin to inflate from center out in a staged inflation.

! WARNING !

**The drogue MUST be deployed before activating the main canopy!
NO DROGUE = NO MAIN**

2.1.2 Reserve Deployment

This section is not intended to be a course in dealing with skydiving emergencies. It is simply a general description of how the Strong Enterprises DHT System emergency parachute is deployed.

When a situation occurs where the main parachute is not functioning properly, it may be necessary to activate the reserve parachute. To do this the parachutist will pull the main cutaway handle located on parachutist's right main lift web to full arm extension. Followed immediately by the reserve ripcord located on the parachutists left main lift web, pulling it to full arm extension.

Pulling the cutaway handle will cause the three ring system on the main risers to release allowing main parachute to detach from the harness. Pulling the reserve ripcord removes the straight pins holding reserve parachute container closed and allows the reserve spring loaded pilot chute to launch from the container.

Attached to left side main riser is a Reserve Static Line (RSL) lanyard. Release of the main canopy (cutaway) will pull the RSL lanyard taut. The RSL lanyard terminates with a ring which is placed around the cable holding the reserve straight pin. Once the RSL lanyard is taut it will pull the reserve pin opening the reserve container. This allows the spring loaded pilot chute to be released. In the event of a low speed malfunction (tension knots, etc...) the RSL will most likely have the reserve container open before the parachutist has a chance to pull the reserve ripcord. ***This does not mean the parachutist can neglect to pull the reserve ripcord.***

Once spring loaded pilot chute has launched it will catch air pulling the freebag bridle clear of the reserve container. The reserve bridle (which is lark's headed into the reserve freebag) then pulls the reserve freebag from the container. As the freebag is pulled further from reserve container the canopy lines are released from their stows and the lines become taut. Once lines reach full extension the freebag is pulled from the canopy and the pilot chute carries the freebag away from the inflating parachute to eliminate any entanglements. The canopy then opens from the center out in the typical manner.

When deploying the reserve parachute, it is recommended that the parachutist be in a stable, belly to earth position. However, some instances require immediate reserve deployment.

Priority One – Pull.

Priority Two – If possible, pull stable.

1. Assume a hard arch position.
2. Look at and grasp the reserve ripcord handle.
3. Pull the reserve ripcord handle to full arm extension.

2.1.3 Malfunctions

This section is only to be used as a general guideline for identifying and dealing with malfunctions. It is not a course of instruction. Only professional training from a current, qualified Strong Enterprises Tandem Examiner using a suspended harness can properly prepare you to manage a malfunction.

! WARNING !

If the drogue did not release after pulling one of the two main drogue release ripcord handles, attempt to release the drogue by pulling the second main drogue release ripcord handle before implementing the emergency procedure described below.

Malfunctions are divided into two categories: total malfunctions and partial malfunctions.

A **total malfunction** is the failure to initiate deployment of the main parachute. Reasons for a total malfunction may include, but are not limited to, a lost or floating ripcord handle a hard ripcord pull or non deployment of the drogue. Because you will be at or near terminal velocity, a total malfunction requires immediate action. The proper procedure is to promptly activate the reserve while remaining in a stable, face-to-earth position.

A **partial malfunction** is a partial deployment of the main parachute. Partial malfunctions can be further subcategorized as high-speed and low-speed. High-speed malfunctions (drogue-in-tow, bag lock, streamer) require quick thinking and immediate action. Low-speed malfunctions (hung slider, line over, broken lines, torn cells and any spinning malfunction) typically allow more time to assess and react to the circumstances. If the decision is made to cutaway from a malfunctioning main parachute and deploy the reserve parachute, use the following procedures:

1. Look at and grasp the cutaway handle with your right hand.
2. Look at and grasp the reserve ripcord handle with your left hand.
3. Peel the cutaway handle from the main lift web and pull to full arm extension.
4. Confirm the canopy has been completely released.
5. Pull the reserve ripcord handle to full arm extension.

Consult the training materials of the Strong Enterprises Tandem Instructor Certification Course or contact Strong Enterprises directly for more detailed emergency procedures.

2.2 Harness Fitting

For more detailed instruction consult the Strong Enterprises Tandem Instructor Certification Course.

2.2.1 Instructor Harness

1. Ensure that all straps are adjusted all the way out and not twisted.
2. Unhook B-12 snaps and let the leg straps hang free.
3. Lift rig up by its main lift webs and put it on as you would a coat.
4. Thread chest strap through friction adapter and tighten until both main lift webs are parallel with each other. Be sure it is not routed through the reserve ripcord handle.
5. Fold and stow excess chest strap in elastic keeper.
6. Route leg straps around your legs, removing all twists and fasten B-12 snaps to their V-rings.
7. Tighten leg straps evenly until they are snug but not uncomfortable and stow excess webbing in elastic keepers.
8. Tighten lower side back strap. The harness should now be fitted and snug.
9. Stow excess webbing of all adjustable straps.

2.2.2 Tandem Student Harness

Following the simple steps below will assure your students safety, and offer them a comfortable Tandem Skydiving experience.

! WARNING !

The student harness must be donned and adjusted completely while on the ground - NEVER in the airplane. Check and double-check proper fit BEFORE boarding the aircraft. Once the student is properly fitted, you should resist the urge to further tighten the MLW in the airplane while the student is seated. Doing so may inhibit the student's ability to arch. Keep other minor adjustments (such as rear diagonals) to an absolute minimum.

It's All About the Student!

2.2.2.1

Extend all adjustments completely out to the stops. In order to properly secure the student harness to varying body size and shapes, it is critical to begin with the student harness fully extended. Help student don the harness and position the harness on shoulders.

NOTE!

If the Strong Student Tandem Harness has "Step In" friction adaptors, with the leg straps fully extended, have the student step into each leg strap prior to passing their arms through the MLW. They may be left extended around the legs of the student during Steps 2 and 3.

**2.2.2.2**

Fasten the chest strap securely and stow excess webbing in elastic keeper.

**2.2.2.3**

Fasten bellyband so chest strap and bellyband are equally snug. The main lift webs should be parallel from shoulder to hip.

NOTE!

Once the chest strap and belly strap are secured, the left and right MLW should be symmetrical and perpendicular to the chest strap and belly strap. The MLW should lay flat down on the chest and torso, in the front of the student, not angled back towards the students hip bone.



2.2.2.4

Tighten leg straps with leg pads just under the buttocks, and apex of leg straps at hips. Stow excess webbing in elastic keepers.



2.2.2.5

Adjusting main lift webs so sewn risers are centered on the shoulder, and butterfly snaps rest just behind the shoulder.



2.2.2.6

Tighten rear diagonals so harness is secure against student's back. Ensure elastic keeper is pulled up to secure loose webbing.

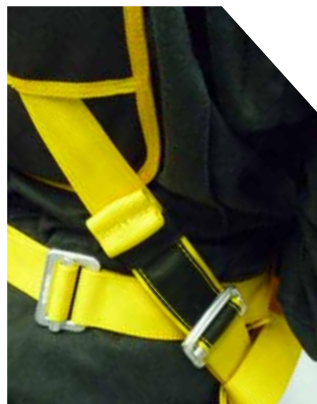

2.2.2.7

Tighten horizontal back strap. The lower harness should now be fitted and snug. Ensure elastic keeper is pulled over to secure loose webbing.

**NOTE!**

As of December 31st, 2007, all Strong Tandem Student Harnesses are required to have the Y-Mod webbing modification that connects the back pad and leg straps together. (If you encounter a Student Harness in the field without a Y-Mod, contact Strong Enterprises before the next jump. Y-Mod field modification kits are available and Strong Enterprises also can perform the modification.)

2.2.2.8

Tighten Y-mod strap located below harness back pad. The Y-mod does not need to be excessively tight to work correctly. Ensure student can still lift their legs with Y-mod secured, if the Y-mod is restricting the student from lifting their legs, loosen the adjustment to allow movement.



2.3 Operator Pre-Jump Inspection

Prior to donning the system, perform an airworthiness inspection.

Check the front side:

- **Risers:** Check that RSL is attached and properly routed. Examine 3-ring and ensure that only one small ring is routed through each larger ring. Make sure none of the rings are bent. Ensure the red loop runs through only the smallest ring, then through the grommet, then through the end of the cable housing and the cutaway cable runs through the red loop. Make sure there are no twists in the red loop.
- **Cutaway Handle and Secondary Drogue Release:** Make sure handle is snug in pocket. Check that Velcro® locations are clean and handle is firmly held in place. Make sure secondary drogue release cable is properly routed through metal loop attached to cutaway handle.
- **Primary Drogue Release:** Make sure primary (student) drogue release ripcord is secured.
- **Reserve Ripcord:** Make sure handle is snug in pocket. Check that Velcro® locations are clean and handle is firmly held in place.
- **Harness:** Check to ensure that the webbing is not damaged. Check the chest strap hardware and the leg strap hardware for rust that might inhibit function and/or damage webbing. Pay close attention to the B-12 snaps on the leg straps, snap the gate open and closed to ensure the spring is still effective and the gate is not bent preventing complete closure.

Check the back side:

- **AAD:** Make sure AAD is turned on. Visually confirm that the LCD screen is reading what is specified by the manufacture to be correct for Tandem jumping.
- **Reserve Container:** Examine that the ripcord pins are seated correctly and seal is not broken. Check the Data card to make sure reserve is in date. Make sure RSL ring is between the two guide rings. Pull slack from cable toward ripcord pins.
- **Main Container:** Make sure the flex-pin is routed correctly starting at drogue riser and passing through housing to exit near first grommet. Ensure both main closing loops are around flex-pin and in good condition.
- **Drogue Riser:** Ensure drogue bridle and ring are faced in the correct direction and that the assembled 3-ring is properly routed with only one small ring routed through each larger ring. Make sure thru-loop only goes through small ring, and each drogue release cable only passes through one loop on the thru-loop.
- **Drogue Bridle Routing:** Check that bridle is free of twists and routed properly.
- **Drogue:** Check that drogue is fit snugly in pouch. Test that the drogue is properly packed by pulling on drogue pud. Ensure that the whole drogue moves with the pud and does not unravel. Reseat the Velcro® securely.

Should you notice any problems, the system should not be used until properly inspected by a certified rigger or equivalent and issues or problems are resolved.

Section Three:

Inspection and Maintenance



3.0 Introduction

This section has valuable information concerning the inspection, rigging, and maintenance requirements for the DHT system. Should you have questions about any of the information contained in this manual please contact Strong Enterprises for clarification. While conducting an inspection, keep in mind that an inspection does not make a parachute system airworthy. The inspection itself is useless unless any identified problems are corrected.

3.1 Care of your Dual Hawk Tandem System

Observe these precautions to maximize the service life of your Strong Enterprises Dual Hawk Tandem System. Use care in handling packed parachutes as metal parts could cause personal injury. Remove all jewelry when packing or performing maintenance on the parachute. Damage to the canopy materials could result from watches, rings, bracelets, etc. Avoid handling the ripcord grip when working with a packed parachute. Use every effort to protect the parachute from the weather elements, dust, dirt, oil, grease, and acids. Place unpacked parachutes in appropriate kit bags. Cover canopy during periods of inactivity. Avoid prolonged exposure to sunlight, inspection lights, or fluorescent lights. Nylon material is subject to deterioration under ultraviolet light. Use a heated building to store parachutes when available. Store parachutes in a dry, well-ventilated location, protected from theft, dampness, fire, dirt, insects, rodents, and direct sunlight.

>CAUTION<
**LEAVING ANY PART OF THIS PARACHUTE SYSTEM
 EXPOSED TO THE SUN WILL GREATLY DECREASE ITS
 LIFE!**

3.2 System Service Life

The expected service life of the Strong Enterprises DHT Parachute System will depend on the care, use, and maintenance of the system. Performing regular inspections and addressing the issues found during those inspections will greatly increase the total life of the system.

For more Service Life information please refer to the Recertification Requirements that can be found on the Strong Enterprises website.

3.3 Inspections and Maintenance

3.3.1 Overall Inspection

Prior to assembling this DHT system, a current and qualified rigger should check:

Packing Data Card. Examine Packing Data Card to verify the information matches the components received.

Assembly completeness. Ensure that assembly is complete and no components are missing.

Operational adequacy. Check components and parts to ensure proper assembly, which includes attachment and alignment, and that assembled product functions in prescribed manner.

Further, ensure that no stitch formation or sewn seam has been omitted.

If your DHT has come pre-packed a qualified rigger or equivalent should inspect to ensure that all parts are complete. That the reserve is sealed and signed. Also that the serial numbers match the documentation and data cards.

3.3.2 Reserve Inspection

The reserve canopy must be thoroughly inspected during every pack as well as after every activation.

3.3.2.1 Reserve Container

Look at the overall appearance of the fabric and binding tape looking for any holes, tears, or broken stitches in the fabric. Stains can be removed with a mild detergent like Woollite. **Never use products that contain bleach!** Inspect all closing flaps, tuck tabs and stiffeners to ensure none are broken, replace if necessary. Inspect all the grommets for rough edges, dents or bends in the metal. Rough edges can be smoothed out with very fine emery cloth; large dents or bends in the metal require replacement. Grasp the grommet with two fingers and try to spin the grommet to ensure that it is still set properly and secured to the container. It should not move at all. Next make sure that a finger nail can not be slid under the rim of grommet (fingernail test), reset if able to slid nail under grommet. Inspect entire length of RSL lanyard for cuts and frays. Inspect nylatron for missing stitches.

3.3.2.2 Reserve Closing Loop

Inspect reserve closing loops for any snags or fraying. Ensure loop is 1" (+/- 1/16") from washer and has correct knots. If necessary replace according to section 3.5.

3.3.2.3 AAD Pocket and Channels

Ensure AAD pouch is secure and there are no missing stitches. Ensure pouch securely holds processing unit. Inspect channels and cutter keepers for missing or broken stitches. Ensure plastic pocket that holds control unit is secure with no broken or missing stitches. Check that the plastic pocket is not broken and that control unit display can be clearly seen through plastic.

3.3.2.4 Risers

Inspect the webbing for signs of wear. Inspect the stitching on the complete riser for unraveling. Inspect the L-Bars for cracks and tightness. Ensure that hand tack is secure and in place.

3.3.2.5 Lines

Inspect the lines for nicks or fraying, and replace if necessary. Inspect the bartacks at the links and at the canopy attachment points.

3.3.2.6 Slider

Inspect the fabric for holes or burns, replace as necessary. Inspect the grommets for burrs, grooves caused by the lines, and separation. Grasp the grommet with two fingers and try to spin the grommet to ensure that it is still set properly and secured to the slider. It should not move at all. Reset if necessary.

3.3.2.7 Fabric:

Check the seams and line attachment points for stitch integrity. This can be done by turning the canopy face up and standing on a chair, hold the top leading edge (nose) of the canopy at shoulder height, spreading each cell apart to look inside. Inspect each panel for damage. Inspect the canopy for holes, tears and burns.

Note!

Using a fan to inflate cells allows an easier and more thorough inspection.

3.3.2.8 Freebag

Inspect all fabric, seams, bartacks, tapes, and attachment points for holes, tears, burns, stains, and loose or missing stitching. Inspect the grommets for burrs and separation, reset if necessary. Grasp the grommet with two fingers and try to spin the grommet to ensure that it is still set properly and secured to the freebag. It should not move at all. Next make sure that a finger nail can not be slid under rim of grommet (fingernail test), reset if able to slid nail under grommet. Inspect the shock cord stows for missing chokers. Ensure shock cord is no longer than 3 1/4" (+/- 1/4").

3.3.2.9 Bridle

Inspect entire length of bridle for any nicks or tears. Inspect all bartacks and stitching for loose or missing stitches.

3.3.2.10 Reserve Pilot Chute

Inspect the mesh for rips and holes. Inspect the tapes for missing stitches. Inspect the fabric for holes or tears. Inspect the spring shape and tension. There should be no excessive bend in the length of the spring. When compressed to 1-inch on a scale the spring should be no less than 18 lbs. Ensure there are no kinks, sharp edges, or burrs in spring. Inspect the grommets for burrs and separation, reset if necessary.

3.3.3 Main Inspection

In packing and maintaining this system, Strong Enterprises highly recommends you do a complete main inspection as often as possible. This helps to keep minor damage and simple repairs from becoming major and expensive issues. The checklist in Appendix C provides a useful tool when completing the inspection. Feel free to make copies of the checklist in order to have a separate sheet for each container and canopy in use.

3.3.3.1 Harness/Container

Hardware: Inspect all hardware for rust that might inhibit the operation of the unit. Inspect for proper hardware. Snap or "click" the gates open and closed on the B-12, butterfly and/or quick ejector snaps to verify they are still operational. Inspect the student side attachment point on the main harness to ensure ring is secure. Inspect the tacking/stitching on the snaps. Inspect all friction adaptors and rings for rough edges, cracks or breaks.

Webbing: Inspect all webbing on harness for cuts or fraying. Inspect all 4 -points and stitching to ensure they are not unraveling. Look at the overall appearance of the harness and try to locate any excessive fading in color by its dull dry look. This is an indication of over exposure to ultraviolet rays which can weaken the webbing substantially.

Grommets: Inspect all the grommets for rough edges, dents or bends in the metal. Rough edges can be smoothed out with very fine emery cloth; large dents or bends in the metal require replacement. Grasp the grommet with two fingers and try to spin the grommet in place to ensure that it is still set properly and secured to the container. It should not move at all. Next make sure that a finger nail can not be slid under rim of grommet (fingernail test), reset if able to slid nail under grommet.

Drogue Riser: Tighten the screws on the separable "L" link that attaches the drogue riser to the diagonal back straps. Ensure the tackings that attach the ripcord cable housings to the drogue riser are secure and have not come loose. Inspect the drogue riser for cuts or frays in the webbing. Inspect rings to make sure all are free of dents, rough edges, cracks and are proper shape (round).

Fabric: Look at the overall appearance of the fabric and binding tape looking for any holes, tears, or broken stitches in the fabric. Stains can be removed with a mild detergent like Woollite.

Never use products that contain bleach!

Main Closing Loops: Inspect main closing loop for any snags or fraying. Ensure loop is 2" long +/- 1/4". If necessary replace according to Section 3.5.

Spandura Drogue Pouch: Inspect drogue pouch, make sure it is secure with no loose stitching. Check for holes or tears in fabric. Ensure the pouch securely holds the drogue.

Elastic: Inspect all keeper locations to ensure they are all present. Replace any elastic that is stretched and no longer functional.

Tuck Tabs and Stiffeners: Inspect all closing flaps, tuck tabs and stiffeners to ensure none are broken, replace if necessary.

Velcro®: Mate all Velcro® to ensure it stays secured. Clean off any grass or dirt that might have accumulated on it. Worn out Velcro® should be replaced.

3.3.3.2 Ripcords, Housings and Cables

Cutaway, Reserve, and Drogue Ripcords: Inspect cutaway handle for completeness of stitching. Ensure stiffeners and plastics are not broken. Inspect hook and pile for loose or missing stitches and debris. Inspect the ripcord cable for kinks, broken strands or rough areas. Check the tip of the cable to insure that no metal cable strands have become exposed. Inspect the reserve ripcord pin to ensure it is not bent. Check that the swages on the cutaway cable and reserve cables are secure and in place. The most common fail spot is where the cable connects to the swedge.

3-Ring Release: Inspect the 400 lb red H.G. line for cuts and frays. Ensure all rings are securely attached with no loose or missing stitching. Inspect rings to make sure all are free of dents, rough edges, cracks and are proper shape (round). Check for proper routing of three ring release system. Make sure to check both main risers and drogue riser.

Cable Housings: Keep cables and housings clean: Pull the release cables out of the housings and make sure there are no kinks or prominent curves in the cable. Pay particular attention where the cable leaves the housing, as a bend or sharp curve may increase pull force as it feeds back through the housing. If the cable shows signs of unraveling it should be replaced. Clean the cables, the inside of the housings, and the braided cord loop on the riser which holds down the small ring, then lubricate using any of the following:

- i) White Lightning - described as a self-cleaning lubricant (www.whitelightingco.com). We found it easiest to just squirt the lubricant into the end of the (cleaned) cable housing since it dries completely. Both parts get lubricated with one simple procedure. Be careful as it may stain fabric.
- ii) SuperLube with Teflon - This is a spray that can be found at auto parts stores. Leaves a dry film of Teflon. (Don't lubricate the loop with Teflon Spray.)
- iii) Silicon spray - Be sure to wipe off the wet silicon with a clean dry rag as this residue will attract contaminant's. (Don't lubricate the loop with Silicon). All cable housings including the small release cable housings should be inspected for damage. Check all tackings to insure they are secure, replace tackings if loose.

3.3.3.3 Main Canopy

Risers: Inspect the webbing at the 3-ring for signs of wear. Any wear at this location can lead to riser failure. Inspect the stitching on the complete riser for unraveling. Inspect the Rapide Links for cracks and tightness. Ensure bumpers are not cracked or worn, and that hand tack is in place and secure. Grommets and rings should be secured with no rough edges. Inspect the stainless steel snap shackle (Swedish link) to ensure it functions properly.

Lines: Check for stretch or shrinkage. The tolerance for line length deviation is plus or minus 1-inch. Symptoms include slow openings and tension knots. Use line trim chart (Appendix A) to check for deviations, re-trim if necessary. Inspect the lines for excessive wear and replace if necessary. When looking at a frayed line that is questionable take into consideration that tandem systems are subject to heavier loads than solo systems. Inspect the bartacks at the links, at the cascades, and at the canopy attachment points. *We have found that at about 3 ft down from the lower canopy surface is where the lines tend to show the greatest wear.*

Slider: Inspect the fabric for holes or burns, replace as necessary. Inspect the grommets for burrs, grooves caused by the lines, and separation. Grasp the grommet with two fingers and try to spin the grommet to ensure that it is still set properly and secured to the slider. It should not move at all. Reset if necessary.

Fabric: Check the seams and line attachment points for stitch integrity. This can be done by turning the canopy face up and standing on a chair, hold the top leading edge (nose) of the canopy at shoulder height, spreading each cell apart to look inside. Inspect each panel for damage. Inspect the canopy for holes, tears and burns and repair as needed. Inspect the bridle attachment point for wear.

Note!
Using a fan to inflate cells allows an easier and more thorough inspection.

3.3.3.4 Drogue and ALS Bag

ALS Bag: Inspect all fabric, seams, bartacks, tapes, and attachment points for holes, tears, burns, stains, and loose or missing stitching. Inspect the grommets for burrs and separation, replace or reset if necessary. Grasp the grommet with two fingers and try to spin the grommet in place to ensure that it is still set properly and secured to the ALS bag. It should not move at all. Next make sure that a finger nail can not be slid under rim of grommet (fingernail test), reset if able to slid nail under grommet. Inspect the Rapide Links for cracks and tightness. Inspect the rubber bands and replace if warped or broken. Ensure shock cord loops are not broken or frayed and are no longer than 3".

Bridle and Deflation Line:

Y-line Style - Inspect the entire bridle for loose stitching and signs of wear. Inspect drogue 3-Ring attachment and main closing pin attachment, replace or repair as necessary. Check for wear at the cotton wrapped end of bridle. Hockey tape can be used to wrap end of bridle, this will help prevent wear. Ensure plastic bumper is in place over Rapide Link, and neither are damaged. The plastic bumper helps to keep the Rapide Link nut from wearing at the bridle. Inspect bartacks on Y-deflation line for unraveling and deflation line itself for wear. Most wear is found at the point where the two pieces of tubular come together in the Y, so check carefully. When replacing the Y-deflation line the new deflation line can be pulled through the bridle, from the top, using the old deflation line by attaching the two together.

1. Cut existing line and lark's head new line to apex attachment point.
2. Tie old line to one end of new line. There is no need to tie both ends. Ensure both are out when finished.
3. Using the bridle opening pull new deflation line through bridle.

Drogue: Starting at the top of the drogue and working down, ensure drogue pud is secure and in tact. Inspect the canopy fabric for holes or tears. Check stitching and bar tacks inside the drogue where deflation lines is attached. Inspect the reinforcing tape for missing stitches. Inspect the mesh for rips and holes. Ensure the zigzag stitching at fabric base is complete.

3.4 Repair Guidelines

When possible, stitching and re-stitching on parachute items should be made with thread that matches the color of the original stitching. All straight stitching should be 7-11 stitches per inch, and locked by over stitching the existing stitching by at least 2-inches. Zigzag should extend at least 1/2-inch into undamaged stitching at each end. Re-stitching should be made directly over the original stitching, following the original stitch pattern as closely as possible. All thread on the canopy should conform to Mil Spec A-A-59826, Size E, and be applied with a light or medium duty machine.

3.4.1 Harness/Container

Any portion of the harness that is structurally damaged should be replaced in a manner to duplicate the original. Container repairs authorized are standard single side patches or replacement of the damaged area.

3.4.2 Main Canopy

Any holes or tears in the canopy fabric should be patched with a single side patch using a French fell seam.

Type of Repair

Re-stitching:

Patch, single side:

Cell replacement:

Reinforcement tape replacement:

Suspension line replacement:

Limitations

No limit as to length or number

Size limit: Maximum 50% of cell surface

Limit of 2 per cell

Factory replacement only

Factory replacement only

No limit (See Appendix A for dimensions)

3.4.3 Reserve Canopy

If any holes, tears, or burrs are detected or if suspension lines are out of trim return canopy to factory or authorized recertification center for complete inspection and evaluation.

3.4.4 Drogue

Unlimited re-stitching. Single side patch maximum of 50% of panel or mesh. Anything more, replace.

3.4.5 Ripcords and Release Handles

Damaged ripcords and release handles should be replaced. Bent pins can be straightened if bend is less than 45 degrees.

3.4.6 Bridles

Damaged bridles must be replaced.

3.4.7 Closing Loops

Damaged Main and Reserve closing loops must be replaced (see section 3.5).

3.4.8 Data Card

Data cards should not be discarded or replaced. When filled, they should be attached to the new card so that a complete history can be maintained.

Note!

Darning and ripstop tape are not authorized for certified canopies as they may weaken the fabric. Single side patches are recommended for even small, damaged areas.

3.5 Closing Loop Construction

Read AAD manual for detailed user specification of closing loop construction.

3.5.1 Reserve Closing Loop

Reserve Closing Loop is made of Dyneema. Total length from washer to loop is 1 inch ($\pm 1/16$ "). To make loop cut a 10" piece of Dyneema. Next thread finger trapping rod through open end of Dyneema. Poke tip of tool out through material and hook opposite end. Pull through center of Dyneema until a $3/4$ inch loop is formed. Thread loop through Cypres© washer and lock in place with a surgeons knot and locking knot. Burn end to lock ends together.

WARNING

Ensure that both ends of Dyneema are caught in the knots, or loop may come apart.

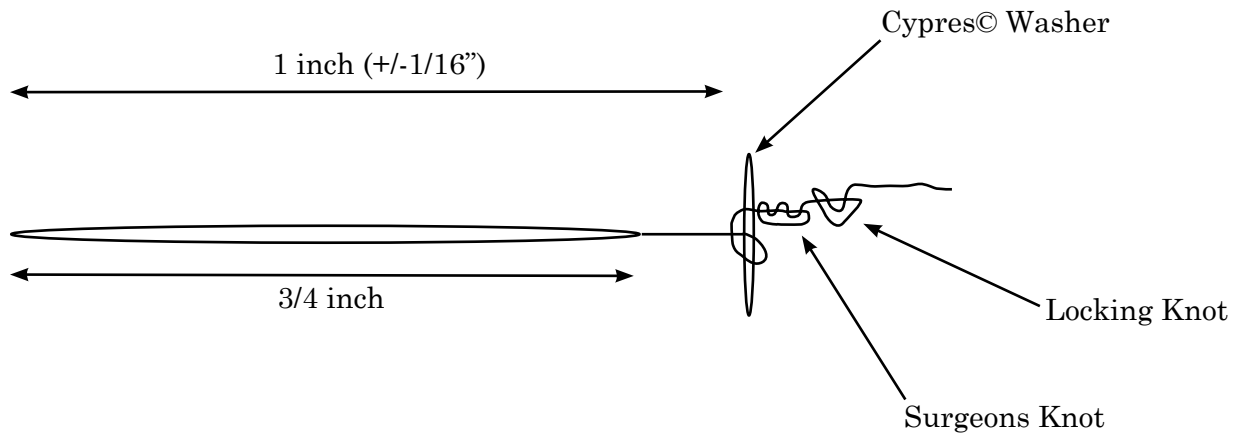

3.5.2 Main Closing Loop

Main Closing Loop is made of 1800 lb flat spectra. Total length from washer to end of loop is 2 inches. To make loop fold a 9" piece of flat spectra in half and lock end with an overhand knot so that loop is 2 inches. A $9/16$ " washer is then slid over the loop to keep the loop from slipping through the grommet.

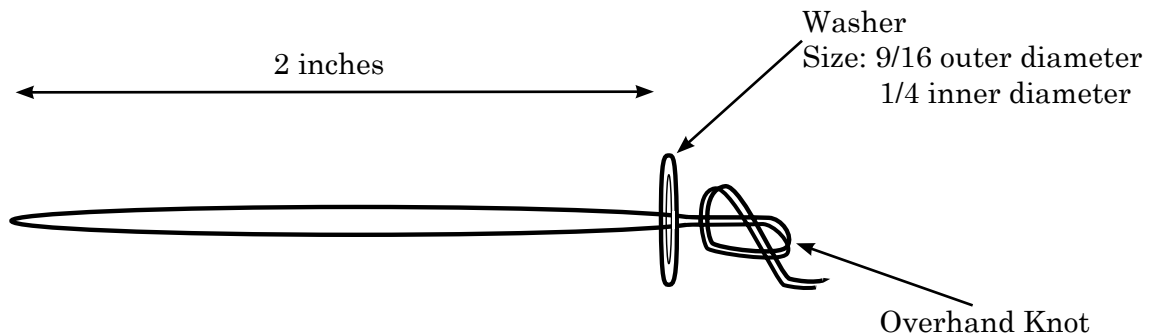

Section Four:

Rigging



4.0 Introduction

This section outlines the manufacturers instructions on how to rig and pack the DHT system, the approved components, and the recommended packing tools. In the U.S.A this system must be packed in accordance with US FAA regulation 105.43 & 105.45 which state:

No person may make a parachute jump with a tandem parachute system unless—

1. The main parachute has been packed within 180 days before the date of its use by a certificated parachute rigger, the person making the next jump with that parachute, or a non-certificated person under the direct supervision of a certificated parachute rigger.
2. The reserve parachute has been packed by a certificated parachute rigger.
3. The tandem parachute system contains an operational automatic activation device for the reserve parachute, approved by the manufacturer of that tandem parachute system. The device must—
 - i. Have been maintained in accordance with manufacturer instructions, and
 - ii. Be armed during each tandem parachute operation.

Outside the U.S.A. local regulations apply as long as the instruction in this manual are followed by an appropriately rated parachute rigger or equivalent using only Approved components.

4.1 Approved Components

Please refer to the most current “Approved Components List” for a current list of approved components for the DHT. The list can be found on the website.

4.2 Packing Tools and Consumables

Tools:

- A - Packing paddle, 1 ea**
- B - AAD approved pull-up cord, 2 ea**
- C - Temporary locking pin, 2 ea**
- D - Screwdriver, flat head**
- E - Seal press**
- F - Knee plate**
- G - Positive leverage closing device**

Consumables:

- H - Lead seal**
- I - Seal thread**
- J - Rubber Bands**



4.3 Preparing the Reserve Container and Canopy

Rigger Qualifications

FAA FAR 105.43 (b) states that only a certificated and appropriately rated senior or master parachute rigger may pack a reserve parachute that will be carried for use aboard an aircraft in the U.S. By following the instructions in this manual, any current, appropriately rated rigger should be able to assemble and pack the Strong Enterprises Master Reserve canopy.

4.3.1 AAD Installation

All AAD channels and pockets are factory-stitched into the rig and no modifications are necessary. Installation requires no tools and can be accomplished by a senior or master rigger using the following technique. For the current list of approved AAD's see the "Approved Components List" available on the website.

4.3.1.1

Following manufacturer instructions, test the unit before installation.



4.3.1.2

Place the processing unit in pouch.



4.3.1.3

Route control unit out from the right side of pouch, through the channel, up to top of the container.



4.3.1.4

Place control unit in clear pocket, on top of the reserve stiffener flap.

**4.3.1.5**

Route right and left cutters, through the left and right channels (1 ea), under the Velcro® and place in elastic keepers on each side flap.

**4.3.2 Attaching Pilot Chute****4.3.2.1**

Route bridle from freebag through loop at base of reserve pilot chute.



4.3.2.2

Bring bridle loop to top of pilot chute and thread over top of pilot chute.



4.3.2.3

Work loop to base of pilot chute and pull bridle tight to lock in place.



! WARNING !
This reserve deployment bag assembly must not be attached to the reserve canopy.

4.3.3 Install Hesitater loop and closing loops

4.3.3.1

Place hesitater loop through center grommet on reserve sub flap. Then place two AAD approved closing loops through the grommets on either side of the reserve sub flap.



4.4 Packing of the Master Reserve Canopy

Parts of these packing instructions are similar to those shown in other manuals. This method has worked best under all speeds and conditions as tested by Strong Enterprises. This procedure utilizes a combination of flopping and stacking the canopy and is the only approved method of packing the Master Reserve canopy.

! WARNING !
PRO packing of the Master Reserve canopy
IS NOT APPROVED.

4.4.1 Canopy Continuity Check

4.4.1.1

Anchor the harness/container so that the container is accessible. Lay the canopy out on it's side. (Pictures are shown with the nose of the canopy to the left, but you may orientate the canopy either to the left or right.)



4.4.1.2

Starting at the risers run each line group up to the canopy ensuring that all lines are clear and that control lines pass through rear slider grommets.



4.4.2 Setting the Brakes

4.4.2.1

Pull the control line through the guide ring located on the rear riser until both brake loops (built into lower control lines) are just above the ring.

Note!

Make sure that control lines are routed through loop at top of riser.



4.4.2.2

Bring the locking loop (located on the riser behind the steel ring) up through both brake loops.



4.4.2.3

Pass locking loop through the guide ring and open the Velcro keeper.

Note!

Pulling both left and right control lines at the same time will help keep the tail neat.



4.4.2.4

Insert the tip of the toggle (the portion of the toggle above the grommet) through the locking loop. Do not go past the grommet.

**4.4.2.5**

Place the tip of the toggle in the elastic keeper and mate the toggle to the Velcro® on the riser.

**4.4.2.6**

S-fold the excess line and lay it next to the toggle.



4.4.2.7

Close the Velcro® keeper around the toggle and excess line.



4.4.2.8

Repeat procedure on the opposite riser.



Note!

Visually check the lines, they should all be straight, with no slack between the canopy and the harness.

4.4.3 Folding the Canopy

4.4.3.1

Position slider near connector links. Clear the canopy with a combing motion, picking up the center seam on the nose and pleating each cell all the way to the tail.



4.4.3.2

Starting at the nose of the canopy, fold (do not stack) the nose over in line with the "A" line group.



4.4.3.3

Next make a half fold between the "A" line group and the "B" line group.



4.4.3.4

Continue with one more fold so that the "A" line group is lying directly on top of the "B" line group. Maintain tension when folding to keep the lines taut.



4.4.3.5

Now move to the tail and with one hand controlling the canopy slide the tail section over to the "D" line group.



4.4.3.6

Take the canopy and gently pull away from the lines. This will bring the attachment points of the tail and "D" lines together while keeping the lines taut.



4.4.3.7

Taking the top of the canopy in one hand and the "D" and control lines in the other lift and place the "D" and control lines on top of the "C" line group.

Note!

Maintain line tension during all stacks by pulling on the canopy.

**4.4.3.8**

Move the slider up to the base of the stabilizers. Make certain that any twists in the lines are ABOVE the slider.



4.4.3.9

There will be a twist in the lines of the “A” line group. This is normal because of the folding of the nose.



4.4.3.10

To remove the twist, **grab the “A” line tabs as a group and gently untwist** the canopy and line tabs.



4.4.3.11

This moves the twist into the canopy fabric allowing the lines to remain clear of all twists.



4.4.3.12

Spread the slider out flat (it will be folded in half span-wise).



4.4.3.13

Fold the corners of the slider down to form a point.



4.4.3.14

Insert slider between the stabilizers. Reach into the slider and spread the folded corners out so that the slider lays flat.



4.4.3.15

Taking the “C”, “D” and control lines in one hand and the top of the canopy in the other lift canopy.



4.4.3.16

Bring canopy over “A” and “B” lines.



4.4.3.17

Then bring back to lay on top of “A” and “B” line groups. This makes an S-fold in the canopy so that all line groups are neatly stacked on top of each other.



4.4.3.18

Open the tail by counting half of the seams and opening as a group.



4.4.3.19

Gently lift the tail to ensure that all control lines are running down the center of the tail section.



4.4.3.20

Dress the tail so that the center of the tail is on top.



4.4.3.21

Pull trailing edge down just below slider grommets.



4.4.3.22

Wrap the tail around each side to make a smooth roll. You know the canopy is tight enough if it is the same width as the free bag.



4.4.4 Packing canopy into the freebag

4.4.4.1

While controlling the lines S-fold the lower portion of the canopy. (approximately 14")



4.4.4.2

Next bring the upper portion of the canopy over the previous fold keeping everything secure.

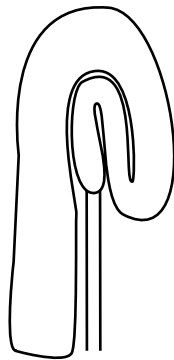

Side View of Folds

4.4.4.3

Position freebag with hesitater loops facing up and closing flap facing down.



4.4.4.4

Slide folded portion of the canopy into the freebag, filling both corners completely.



4.4.4.5

Tightly roll the remaining canopy, being cautious not to pull canopy out of freebag.



4.4.4.6

Tuck rolled canopy into freebag. This fills out the bag and give a nice wedge shape.



4.4.4.7

Make sure that lines are exiting from the center of the freebag.



4.4.4.8

To close the freebag route the center locking bungee stow through the respective grommet and lock with a 1-1/2" bight of suspension line. Push plastic sleeve up to meet suspension lines.



Note!

Make sure the plastic sleeves are installed properly by stretching the bungee to its fullest capacity then sliding the plastic sleeve up as close to the bight of suspension line as possible.



4.4.4.9

Close the second center locking bungee in the same manner as the first with a 1-1/2" bight of suspension line.



4.4.4.10

To finish closing the closing flap continue in the direction of last stow and lock outside locking bungee with a 1-1/2" bight of suspension line.

**4.4.4.11**

In the same manner, stow the remaining outer locking stow.

**4.4.4.12**

Stow the remainder of the lines in the side locking bungees until lines are within 12 inches of the connector links.

***Note!***

Stows should be no longer than the bound edge of the freebag.

4.5 Closing the Reserve Container

4.5.1 Closing the Sub-flaps

4.5.1.1

Bring the risers and freebag over the reserve container, laying the freebag in the main pack tray. Spread the risers along the bottom of the pack tray so that the toggles are outboard and the risers form a "V" shape.



4.5.1.2

Fold the freebag back on top of the risers. Keep the lines neat while folding the freebag back over the risers.



4.5.1.3

Using a pull up cord route the elastic hesitater loop through the center grommet of the bottom sub flap.



4.5.1.4

Make a bight of the bridle no more than 1-1/2" through the elastic hesitater loop.

**4.5.1.5**

Close the sub flaps by using AAD approved pull-up cords and routing them through the grommets on the lower sub flap.

**4.5.1.6**

Pull closing loops through grommets and insert temporary pins.



4.5.1.7

Close the side flaps next by mating the Velcro® at each lower corner of the container.



Note!

To get a nice fit bring bottom corner up around freebag and hold in place while tucking opposite top corner of freebag into top corner of container.



4.5.1.8

Route pull up cord through the AAD cutters and then through the grommets on each respective side flap. Pull closing loops through and lock with temporary pins.



4.5.2 Packing the Pilot Chute

4.5.2.1

S-fold the pilot chute bridle on top of the bottom sub flap vertically using approximately seven-inch folds.

Note!

To make packing easier route pull up cords through their respective grommets on the bottom closing flap before compressing pilot chute.



4.5.2.2

Take the folded pilot chute bridle and move slightly to one side. Fan out pilot chute bridle evenly between the grommets.



4.5.2.3

Place the knot connecting pilot chute to bridle centered on top of fanned out bridle.



4.5.2.4

Position the pilot chute centered between the side flap grommets and compress pilot chute at the bottom of the reserve container. Make sure that all pilot chute fabric is compressed inside the spring.



4.5.2.5

Bring bottom closing flap over pilot chute and, using pull up cords pull closing loops through grommets. Lock in place with temporary pins.



Note!

After locking in place make sure no fabric from pilot chute is between closing loop and pilot chute top.



4.5.3 Closing top flaps

4.5.3.1

Route pull up cords through their respective grommets on the top reserve closing flap.



4.5.3.2

Locate the guide rings on the top reserve closing flap and the two ripcord cables. Route both ripcord cables through the top guide ring (the one located closer to the ripcord cable housing) then through the ring on the RSL lanyard then through the bottom guide ring.

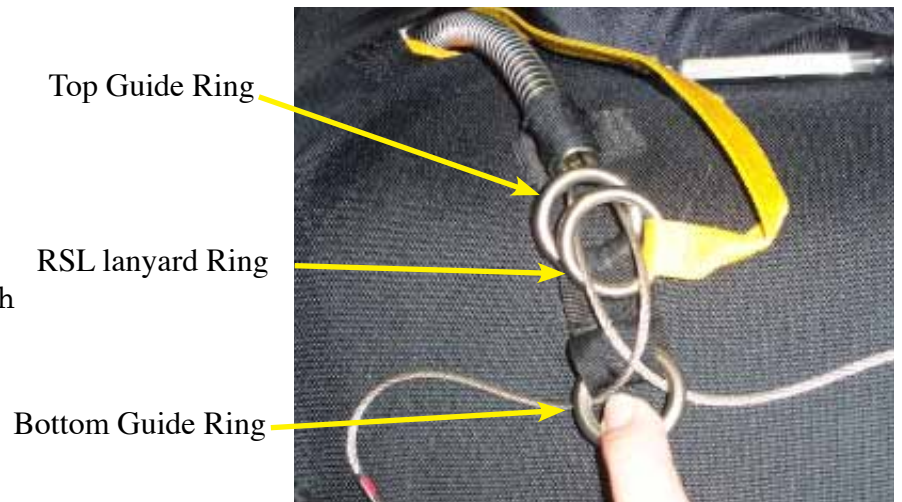

4.5.3.3

Pull right side closing loop through top reserve closing flap and lock with longest reserve ripcord cable pin.



4.5.3.4

Pull left side closing loop through top reserve closing flap and lock with remaining reserve ripcord cable pin.



4.5.3.5

Remove pull up cord. To avoid possibly breaking closing loop, first route pull up cord under ripcord pin and then slowly remove pull up cord. Makes sure that ripcord pins are facing inward to avoid possible snags.



4.5.3.6

The RSL lanyard is laid next to the ripcord cable housing along the top reserve closing flap to the inside of the left riser cover.



4.5.3.7

Secure RSL by placing tuck tabs from RSL lanyard into channels located under left riser cover. Insert top tab first and then bottom tab.



4.5.3.8

Close the reserve riser covers over the reserve risers by placing the tuck tabs around the risers.



4.5.3.9

Close both riser covers. Make sure not to catch the RSL when closing the cover.



4.5.3.10

Seal the furthest pin from the cable housing (right). Fill out the data card and personal log, and close the pin protector flap by folding the tuck tabs around the reserve closing flap.



**CAUTION
COUNT YOUR TOOLS!**

4.6 Preparing the Main Canopy

Tandem mains are jumped by two people; therefore, reliability and confidence levels dictate that the parachute be packed according to the manufacturer's instructions by current and competent riggers/packers, thoroughly trained in this procedure. The person packing this parachute must be completely familiar with ram-air type parachutes, preferably checked out as a Strong Enterprises Certified Tandem Instructor.

According to FAR 105.43: The main parachute of a tandem system must have been packed within 180 days before the date of its use by a certificated parachute rigger, the person making the next jump with that parachute, or a non-certificated person under the direct supervision of a certificated parachute rigger.

4.6.1 Assembling the Drogue

4.6.1.1

Lay ALS bag flat with #3 flap and the drogue release ring facing up. Install rubber bumper over bridle. Attach Kevlar drogue bridle to #5 Rapide link on top of the ALS bag. Tighten nut, finger tight plus 1/4 turn with a 3/8" wrench.



4.6.1.2

Slide plastic bumper over link and handtack in place with two turns through the link bumper and the bridle.



4.6.1.3

Feed Y-lines through #4 grommet on either side of the Rapide link.



4.6.1.4

Attach y-lines to the #5 Rapide link on top of the canopy. Tighten nut, finger tight plus 1/4 turn with a 3/8" wrench.



4.6.2 Attaching Main Risers

4.6.2.1

Lay risers with toggle side facing up above the container. The riser with the Swedish link should attach to the left side.



4.6.2.2

Place the medium ring from the risers down through the 3-D ring. Next bring the small ring from the riser down through the medium ring. Then bring the red loop around the small ring only and run it through the grommet.



Note!

Make sure that small ring ONLY goes through medium ring and that red loop ONLY goes through small ring.

4.6.2.3

Run the red loop through the fitting on the end of the housings and lock in place using the cutaway cables. The excess cable can then be put into the housings on the risers. Connect reserve static line lanyard to the snap shackle located on the left riser.



Note!

Use of RSL is optional.

4.6.2.4

Ensure there are no twists in the line groups by taking each line group and control line group in your hands and follow them up to canopy.

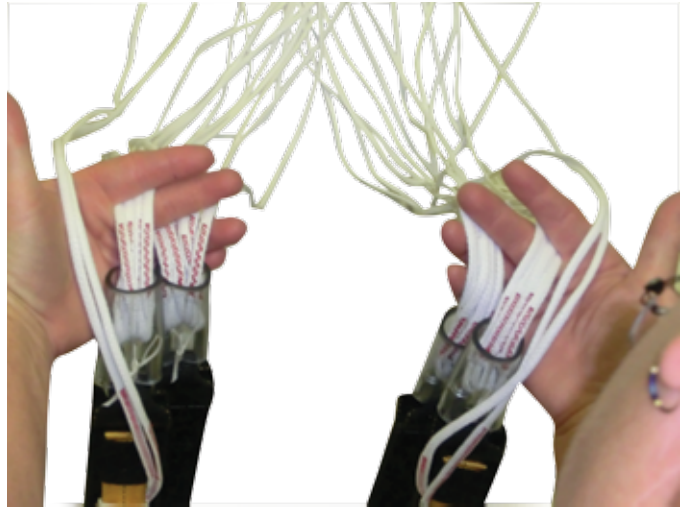

4.6.3 Install Closing Loops

4.6.3.1

Place one closing loop through each of the two grommets on the bottom closing flap. Same length is used in both locations.



4.7 Packing the Main Canopy

4.7.1 Setting the Brakes

4.7.1.1

Pull the control lines through the guide ring until the brake loop is just below the steel guide ring on the rear riser.



4.7.1.2

Bring the locking loop (located on the riser) up through the brake loop.



4.7.1.3

Bring the locking loop up through the guide ring on the riser.



4.7.1.4

Clear the second control line by gently pulling the line back through the ring.



4.7.1.5

Insert the tip of the toggle through the locking loop and stow in elastic keeper located on riser.

**4.7.1.6**

Snap the toggle to the riser, then fold the toggle between the middle and lower hand grip loops and tuck the lower end of the toggle into the toggle pocket located on the riser. S-fold the excess control line and stow in the elastic keeper under the toggle.

**4.7.1.7**

Repeat procedure on the opposite riser.

**CAUTION**

THE LOOP ON THE RISER MUST BE USED IN ORDER TO KEEP THE BRAKE LINE LOOP FROM DIGGING INTO THE SIDE OF THE TOGGLE, MAKING BRAKE TOGGLE RELEASE ALMOST IMPOSSIBLE DURING A MALFUNCTION. THE INNER CONTROL LINES ARE NOT "BRAKED"!

4.7.2 Flaking the Canopy

4.7.2.1

At the risers, pick up the lines and use your fingers to separate the front lines, rear lines, and control lines.

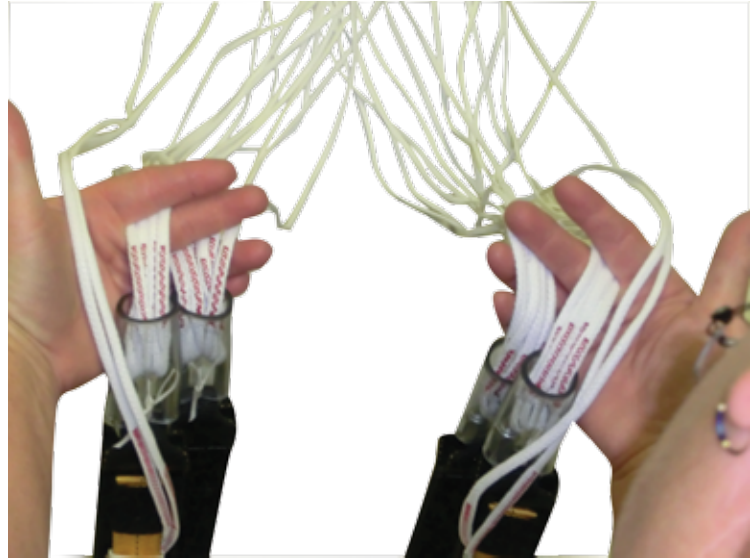

4.7.2.2

While facing the canopy, and still using your fingers to keep the lines separated, walk forward pushing the slider ahead of you until it is seated against its stops.



Note!

At this point you may use a hook to hold the canopy in place or you may put the canopy over your shoulder to hold it.

4.7.2.3

Place the canopy on a hook or over your shoulder and flake the nose. This is done by running a hand down each cell and pulling the cell slightly. This will also align all "A" line tabs so they are even.



4.7.2.4

On each side of the canopy attach a rubber band to the third control line attachment tab from the outside.

**4.7.2.5**

Stow the two left inner control lines in the left rubber band and the two right inner control lines in the right rubber band, using a double wrap.

Note!

Failure to stow inner control lines greatly increases the chance of a "line over" malfunction.

**4.7.2.6**

Reach down into the right side of the canopy between the "A" and "B" lines and pleat all material out from between the line attachment tabs, this should include 5 lower tapes and the stabilizer. Again reach down into the right side of the canopy between the "B" and "C" slider stops and pleat all material out from between those line attachment tabs, this should also include five lower tapes and the stabilizer. Pleat the small section of stabilizer out from between the "C" and "D" slider stops. Ensure that all "D" lines are pulled into the center of the canopy and are clearly visible. Dress the left side of the canopy in the same manner.



4.7.2.7

Quarter the slider so that it is ready to cup air the moment it is deployed. Make sure that the four corners are spread and ensure that the slider pocket is out in front of the nose.

**4.7.2.8**

In order to soften the openings on new canopies you can roll the nose once the canopy gets broken in there is no need to do anything with the nose other than to let it hang down naturally, grasp it and push it into the canopy folds a few inches.

**4.7.2.9**

Locate the center of the tail near the warning label and pull it up so that it covers the slider grommets.



4.7.2.10

Swing the tail seams around the canopy so that they meet in front of the nose and roll them together several times.



4.7.2.11

While keeping the tail seams held firmly in your hand, carefully lay the canopy down flat on the packing surface with the lines taut. Purge the air from the canopy and dress to the approximate width of the deployment bag.



4.7.2.12

S-fold the lower canopy by grasping at the lines and folding up approximately 10-inches.



4.7.2.13

Make your next S-fold by folding the upper canopy back over the first fold keeping everything neat and secure with your other hand. Fold the canopy once back on top of itself and completing the S-fold. Tuck the remaining bit under and to the center.

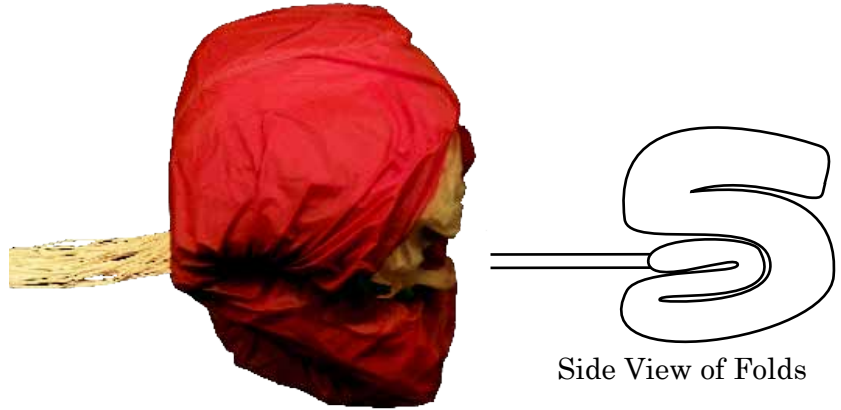

Side View of Folds

4.7.3 Placing the canopy in the ALS bag**4.7.3.1**

While controlling the canopy slide the ALS bag under the folded canopy with the 3 locking bungee stows toward the packing surface. Bring the ALS bag around the canopy making sure to fill out the corners.

**4.7.3.2**

Make your first line stow by bringing the center inner rubber band up through the center grommet and locking in place with a bight of suspension line. Continue with the two side stows closing the canopy in the bag.

***Note!***

If you have a Velcro ALS bag you would now close the Velcro around the canopy.

4.7.3.3

Stow the remainder of the suspension lines to within about 4 feet of the links using rubber bands on sides of the bag. Keep stows neat and only the width of the bag.

**4.7.3.4**

Fold the ALS flap down over the suspension lines. Starting with the outside stows bring the bungee loop through the outside grommet and lock in place with a bight of suspension line. Continue with the opposite outside stow and finish with the center stow.

***Note!***

After the canopy has been jumped, several feet of deflation line will be protruding from the bridle of the drogue. Before the bag can be packed into the container, this line must be pulled back inside the bridle. This is done by grasping the drogue deployment pud (located at the apex of the drogue canopy) and extending the drogue bridle to its fullest length. Doing this will pull the deflation lines back inside the bridle.

4.8 Closing the Main Container

4.8.1 Hooking up the Drogue

4.8.1.1

Bring the deployment bag over the reserve and place into the container with the lines facing down.



4.8.1.2

Dress the risers neatly along the outside of the reserve container and lay the lines neatly in the bottom of the pack tray.



4.8.1.3

Next push the top corners of the ALS bag into the top corners of the main pack tray so that the ALS bag is laying flat in the container. Route drogue bridle to bottom of container and back towards top.



4.8.1.4

Locate the ring on the drogue bridle and lay the bridle and the ring on the ALS bag so that the label reading "This Side Faces Reserve Container" is facing the reserve container.

**4.8.1.5**

Attach the drogue bridle by placing the medium ring from the drogue riser (located between the main and reserve pack trays) through the ring from the drogue bridle. Next place the small ring through the medium ring and lock in place using the thru-loop.

Note!

Make sure that small ring ONLY goes through medium ring and that thru-loop ONLY goes through small ring.

**4.8.1.6**

To secure the thru-loop in place open the Velcro on the back of the drogue riser and insert the drogue release cable into the loop and through the channel. Close Velcro around drogue release cables.



4.8.1.7

Insert the flex pin located on the drogue bridle into the housing located on the drogue riser. Next route a pull up cord through the uppermost closing loop of the bottom flap and through the uppermost grommet on the top flap. Lock in place using the flex pin from the drogue bridle and remove pull up cord.

**Note!**

Make sure that drogue bridle is exiting to the right of the top flap.

Note!

Loop closest to the housing is loose and is a redundant safety feature on the two-loop system.

**4.8.1.8**

Lay the drogue riser along the channel between the main and reserve pack trays. Tuck the extra bridle under the bottom flap. Route drogue bridle out right side of container.

Run a pull up cord through the bottom closing loop from the bottom flap and up through the lower grommet on top flap.

**4.8.2 Closing container flaps****4.8.2.1**

Next close the right side flap by bringing the pull up cord through the grommet on the right side closing flap and pulling closing loop through grommet. Hold in place using flex pin.

4.8.2.2

Close the left flap by bring the pull up cord through the grommet on the left closing flap and pulling the closing loop through. Lock in place with the flex pin.



4.8.2.3

Remove the pull up cord by gently pulling it out. Do not route the cord under the flex pin as, over time, doing so will create a groove in the coating of the flex pin and decrease it's life.



4.8.2.4

Stow the excess flex pin in the pocket provided. Close the flex pin protector flap and stow in its pocket.



4.8.2.5

Route the bridle down the container on the right cover flap channel.



4.8.2.6

Close the bridle cover flap by tucking it into the space provided.



4.8.2.7

Close the center flap by gently tucking it under the main closing flaps.



4.9 Packing the Drogue

4.9.1 Folding the Drogue

4.9.1.1

Remove all the twists in the bridle; check to make sure the drogue is armed and neatly lay the drogue out flat and smooth with the Velcro® at the deployment pud facing upwards.



Note!

Fold near the bottom of the container so you can easily gauge the final size of your folded drogue with reference to the drogue pouch.

4.9.1.2

Make your first fold in the drogue, folding it a little more than in half so that the base (shown black in picture) is just above the drogue pud.



4.9.1.3

Next bring the drogue body up to the base. All the mesh should now be inside the folds of the drogue.



4.9.1.4

Fold the base over the folded body exposing the drogue pud.

**4.9.1.5**

S-folds with the bridle on top of the base, leaving approximately 18"-24" of the bridle unfolded.

**4.9.1.6**

Now fold a small portion of the body over half the S-folded drogue bridle, again using the bottom of the container to gauge the final size of your folded drogue.

**4.9.1.7**

Fold the drogue into thirds leaving the drogue pud in the center of the folded drogue. Folding the sides so they are at an angle towards the pud will even out the materials and distribute the bulk evenly.



4.9.1.8

Fold the other side over the first. Make sure that the drogue pud is centered.



4.9.1.9

Roll it up tightly from one side to the other. Remove any twists from the Kevlar bridle.



4.9.1.10

Turn the container on its side and stow the excess drogue bridle in the drogue pouch.



4.9.1.11

Stow the drogue in the pouch so that the drogue pud remains outside the pouch.

Note!

The open side of the drogue should be placed along the bottom of the container. This way the relative wind helps keep the drogue rolled during bridle stretch.

**4.9.1.12**

Mate the Velcro on the drogue pud to the container.

**4.9.1.13**

Stand the system up and close the riser covers. Inspect the entire assembly.

**COUNT YOUR TOOLS!**

Section Five:

Appendices



Appendix A - Line Charts

A-1 General Line Installation SET-400 and SET-366 Main Canopy

Color Codes on suspension lines:

- A - Green
- B - Blue
- C - Black
- D - Red

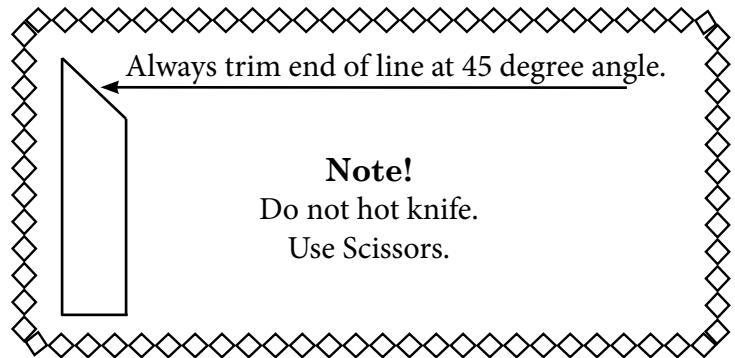

Suspension Lines

Insert B/D line at insertion mark.
Line up with mark on A/C line.
Pull line out approximately 4.5" down.
Ziz-zag, double-throw (308)
Pull out end of line and cut off in a 45 degree angle at cut-off mark.

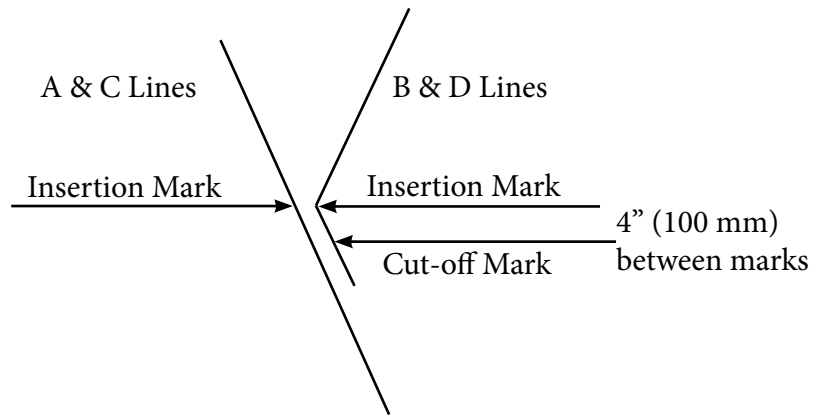

Control Lines E1 and E2 (two uppers)

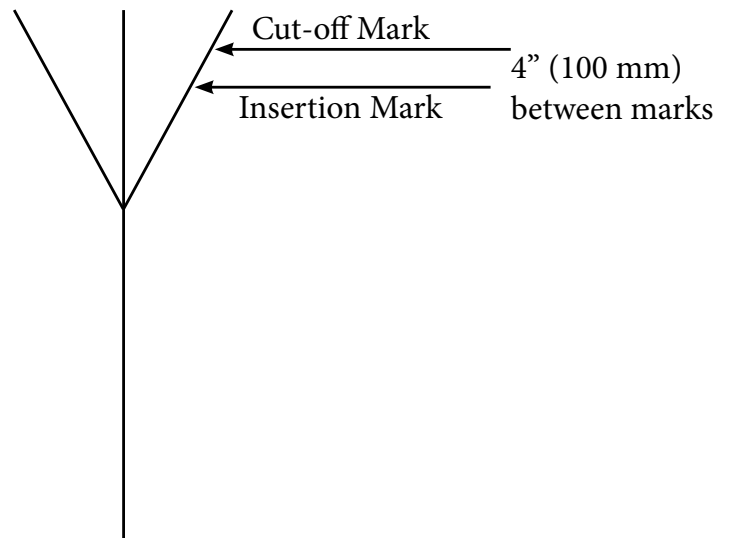

A-2 SET-400 Main Canopy Outer Line Length Ribs 1,2,3,8,9,10

Measurements are installed on canopy with brakes set.

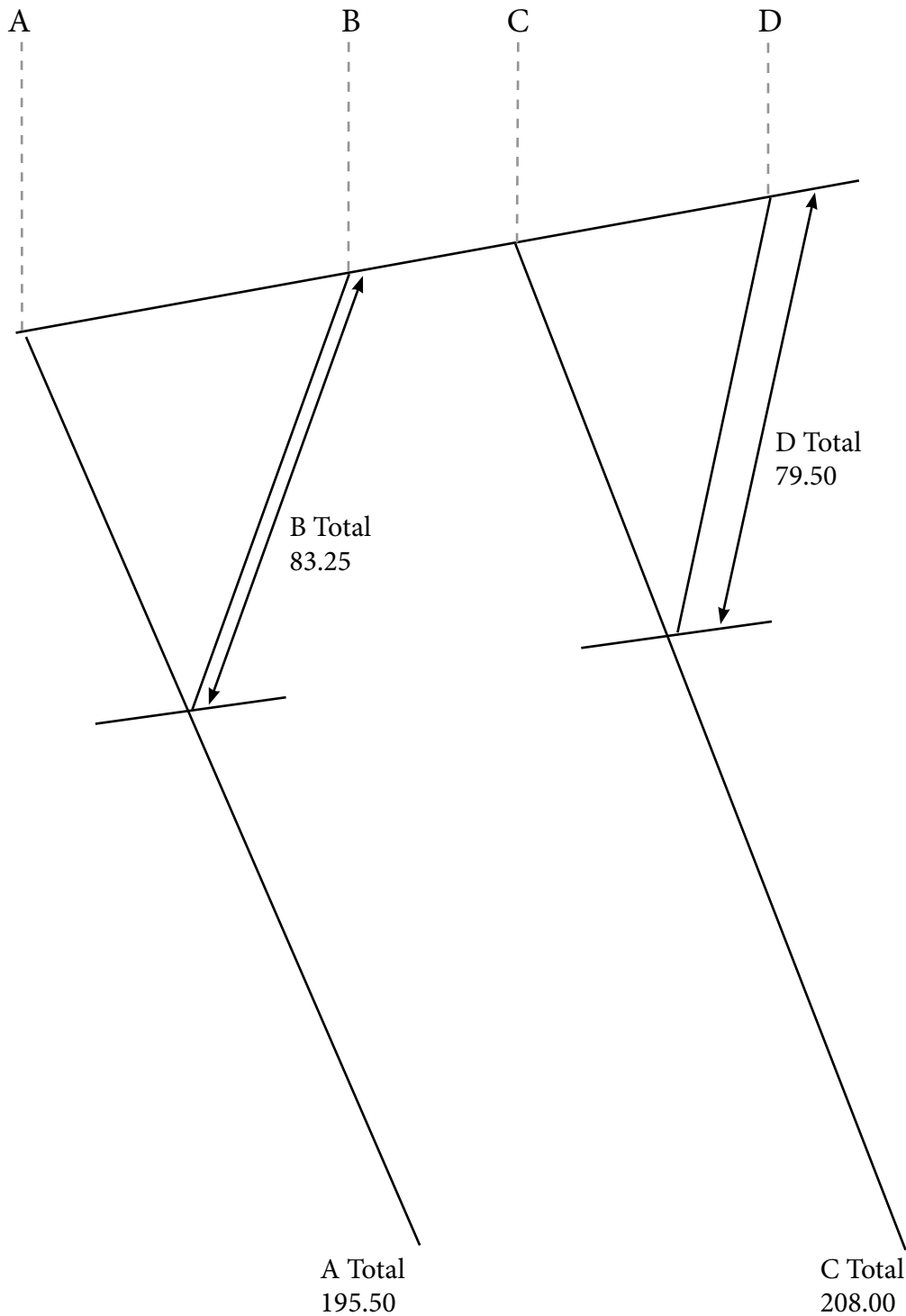

A-3 SET-400 Main Canopy Inner Line Length Ribs 4,5,6,7

Measurements are installed on canopy with brakes set.

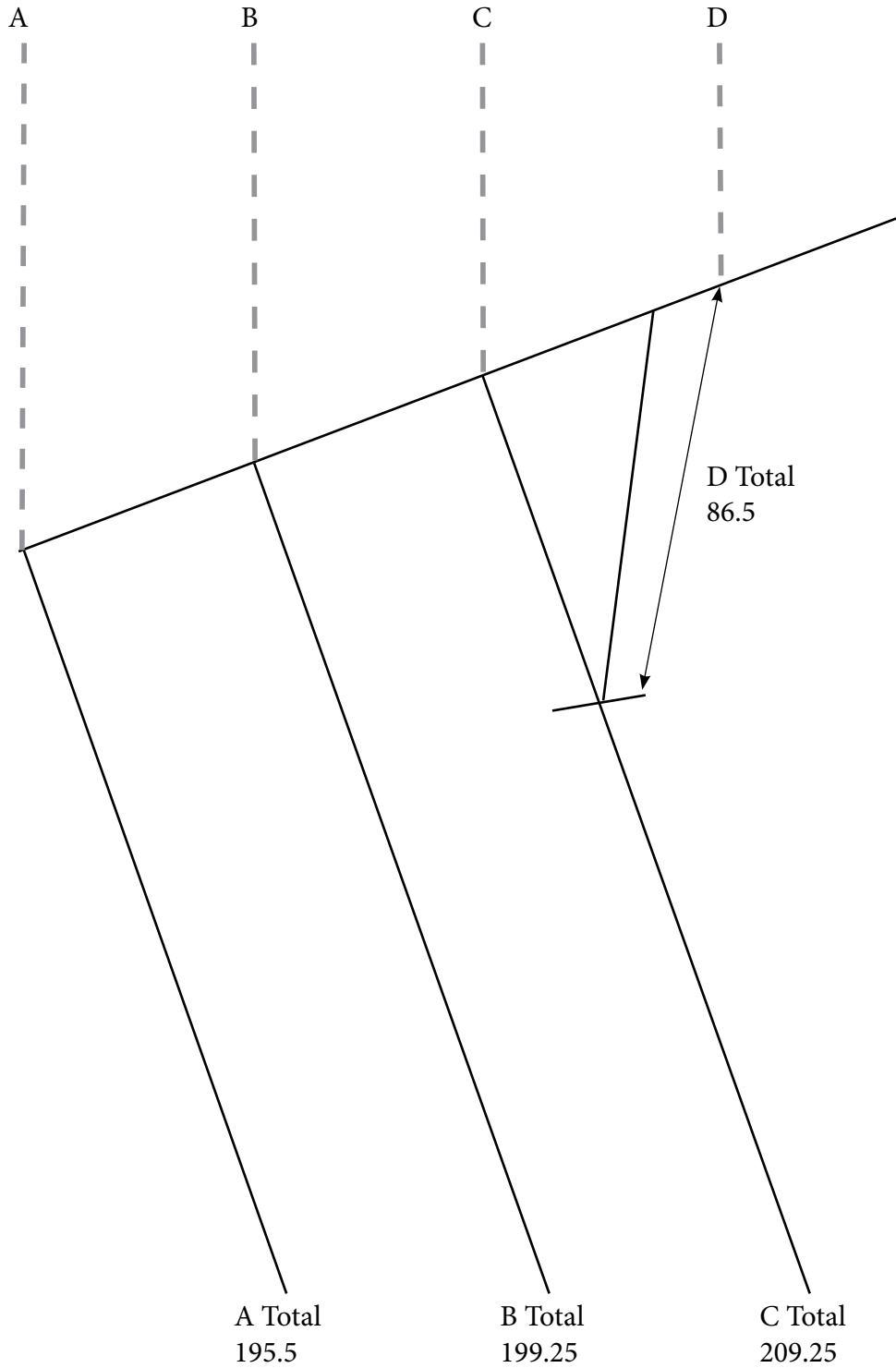

A-4 SET-400 Main Canopy Control Line Attachment

- Denotes Structural Rib
- - - Denotes Soft Rib

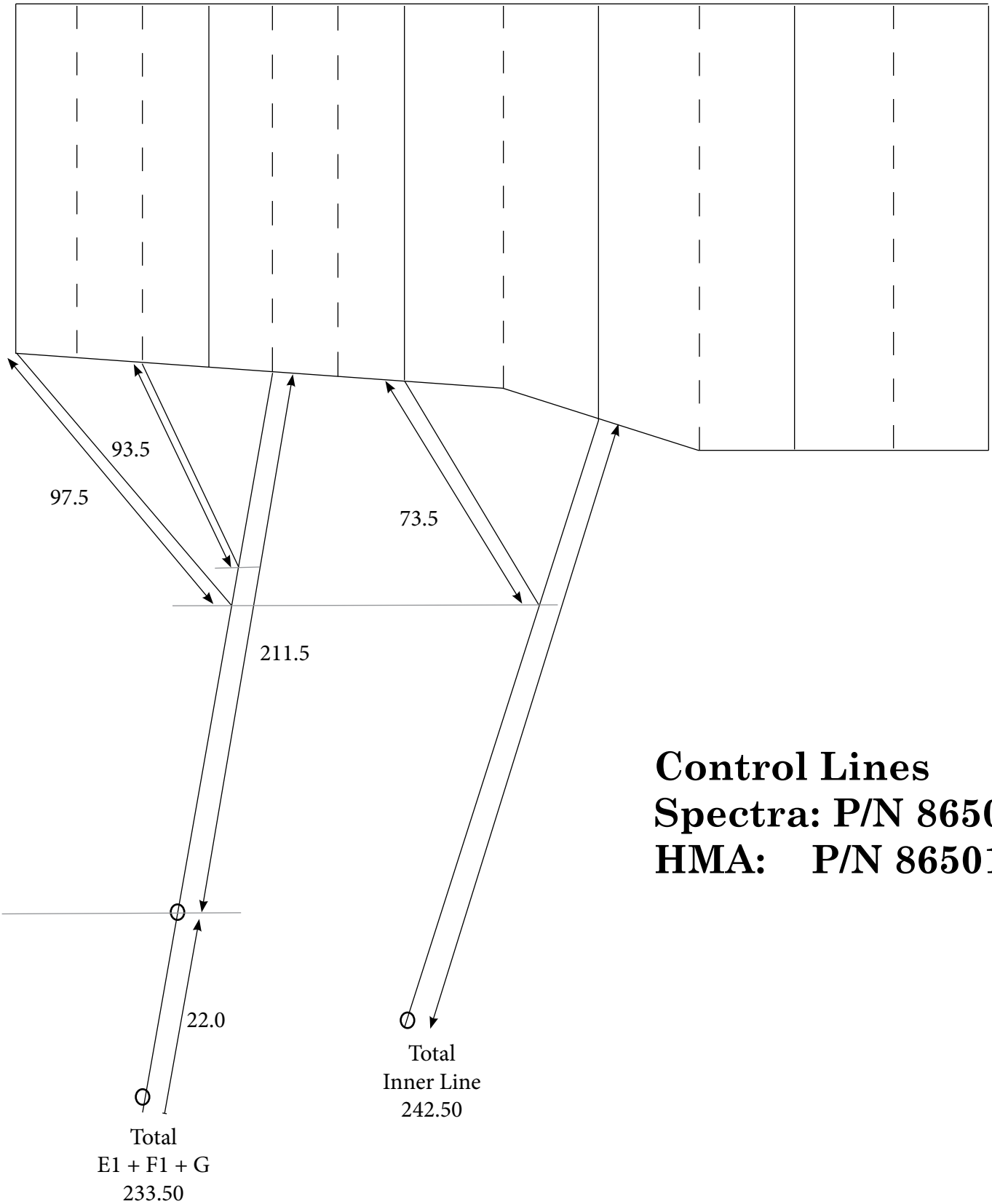

Control Lines
Spectra: P/N 865013
HMA: P/N 865014

A-5 SET-400 Line Dimensions

SN _____

Date Inspected _____

Inspected By _____

How to use this chart

- 1) Measure the individual line
- 2) Write the measurement in the space provided below the recommended length
- 3) Subtract the two numbers. This is the amount the line is out of trim

	L	E	A	D	I	N	G	E	D	G	E	
A	195.50	195.50	195.50	195.50	195.50	195.50	195.50	195.50	195.50	195.50	195.50	195.50
B	199.50	199.50	199.50	199.25	199.25	199.25	199.25	199.25	199.25	199.25	199.25	199.50
C	208.00	208.00	208.00	209.25	209.25	209.25	209.25	209.25	209.25	209.25	208.00	208.00
D	219.00	219.00	219.00	222.75	222.75	222.75	222.75	222.75	222.75	222.75	219.00	219.00
CL	233.50	233.50	233.50	239.50	239.50	239.50	239.50	239.50	239.50	239.50	233.50	233.50

Notes:
 All lines measured from one end to the other
 Control lines are measured without the toggle
 Like dimensioned lines should not vary more than 2"



A-6 SET-366 Main Canopy Outer Line Length Ribs 1,2,3,8,9,10

Measurements are installed on canopy with brakes set.

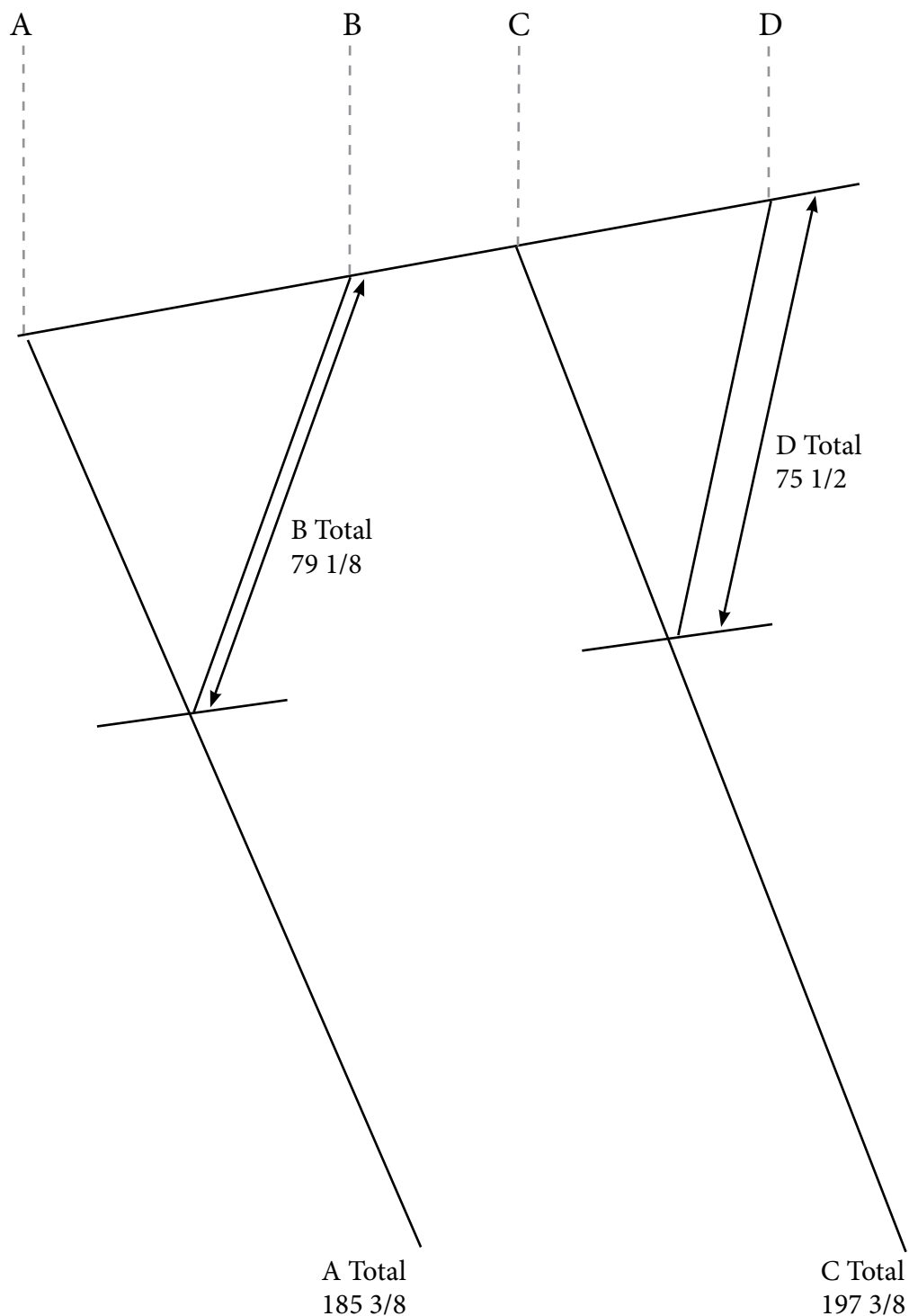

A-7 SET-366 Main Canopy Inner Line Length Ribs 4,5,6,7

Measurements are installed on canopy with brakes set.

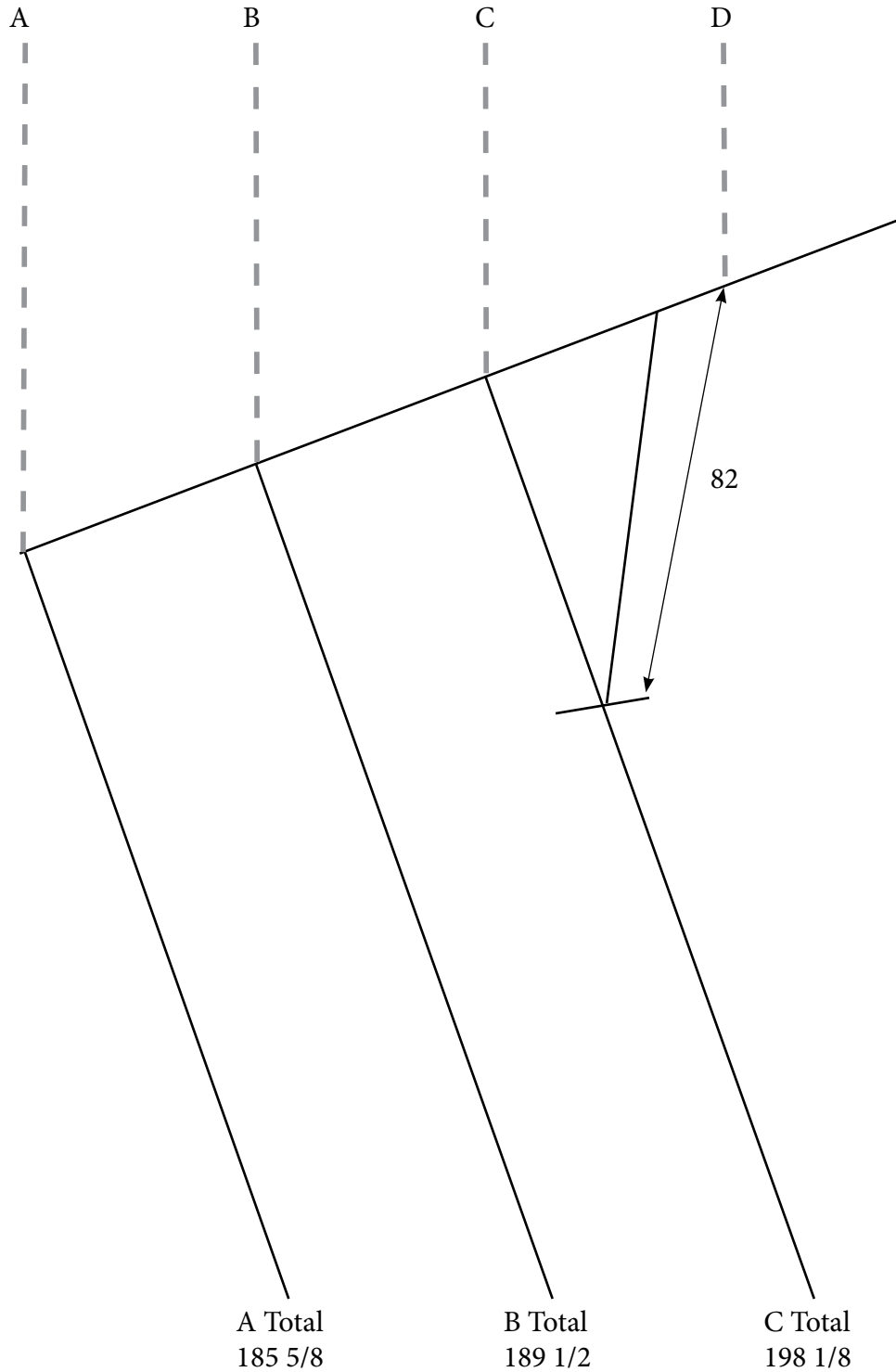

A-8 SET-366 Main Canopy Control Line Attachment

- Denotes Structural Rib
- - - Denotes Soft Rib

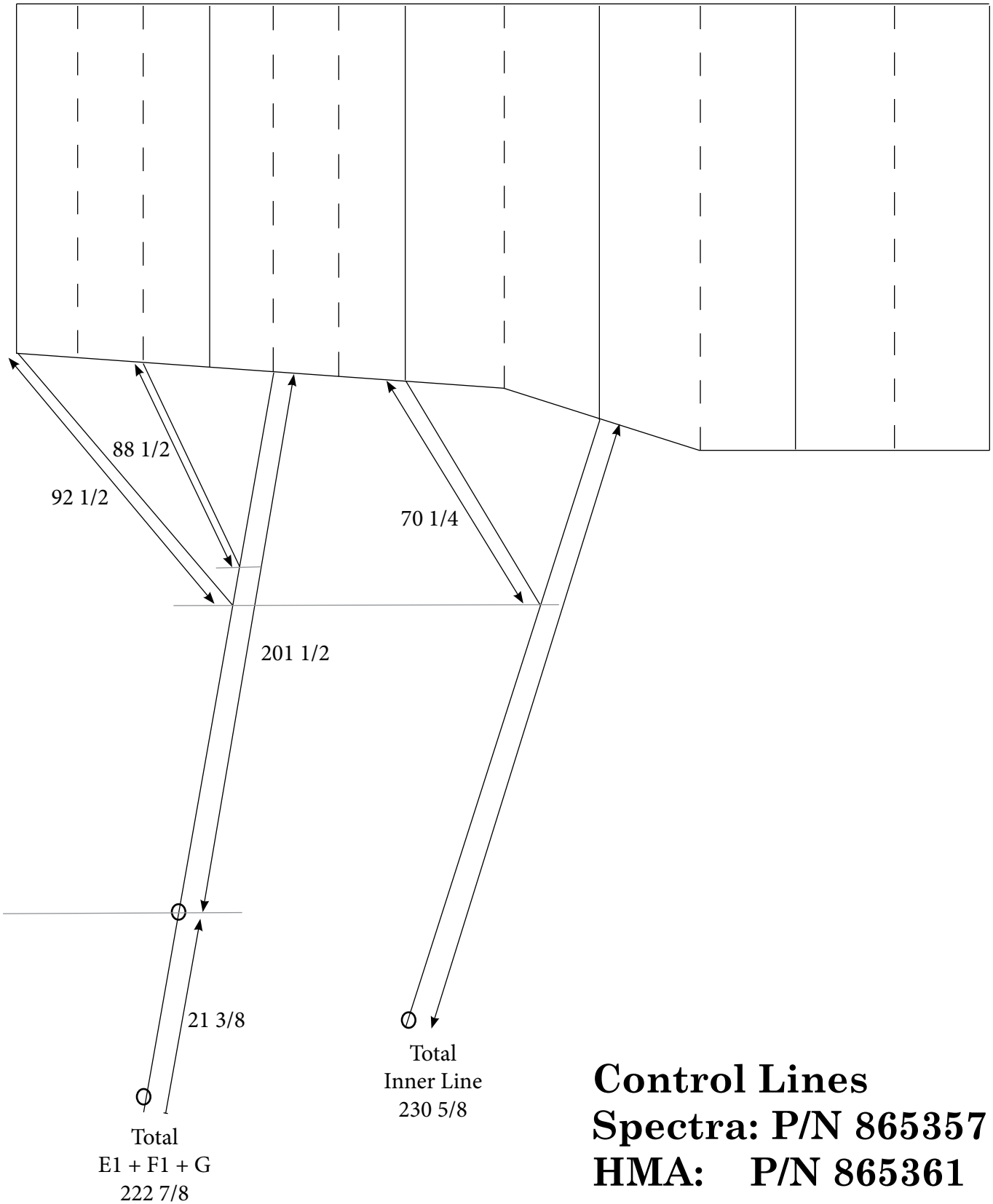

Control Lines
Spectra: P/N 865357
HMA: P/N 865361

A-9 SET-366 Line Dimensions

SN _____

Date Inspected _____

Inspected By _____

How to use this chart

- 1) Measure the individual line
- 2) Write the measurement in the space provided below the recommended length
- 3) Subtract the two numbers. This is the amount the line is out of trim

	L	E	A	D	I	N	G	E	D	G	E	
A	185 3/8	185 3/8	185 3/8	185 3/8	185 3/8	185 3/8	185 3/8	185 3/8	185 3/8	185 3/8	185 3/8	185 3/8
B	188 3/4	188 3/4	188 3/4	189 1/2	189 1/2	189 1/2	189 1/2	189 1/2	189 1/2	189 1/2	189 1/2	188 3/4
C	197 3/8	197 3/8	197 3/8	198 1/8	198 1/8	198 1/8	198 1/8	198 1/8	198 1/8	198 1/8	198 1/8	197 3/8
D	208 3/8	208 3/8	208 3/8	210 3/4	210 3/4	210 3/4	210 3/4	210 3/4	210 3/4	210 3/4	210 3/4	208 3/8
CL	222 7/8	222 7/8	222 7/8	227 3/4	227 3/4	227 3/4	227 3/4	227 3/4	227 3/4	227 3/4	227 3/4	222 7/8



Notes:
 All lines measured from one end to the other
 Control lines are measured without the toggle
 Like dimensioned lines should not vary more than 2"

1/8 = 0.125	1/4 = 2/8 = 0.25
3/8 = 0.375	1/2 = 4/8 = 0.5
5/8 = 0.625	3/4 = 6/8 = 0.75
7/8 = 0.875	

APPENDIX B: TSO Letter for Dual Hawk Tandem System



U.S. Department
of Transportation
**Federal Aviation
Administration**

Central Region
Atlanta Aircraft Certification Office
1075 Inner Loop Road
College Park, Georgia 30337

FEB 27 1985

Mr. Edward Strong
President
Strong Enterprises
11236 Satellite Blvd.
Orlando, Florida 32809

Dear Mr. Strong:

This is in response to your July 31, 1984, request for Federal Aviation Administration (FAA) authorization to identify the Strong Enterprises' Dual Hawk Tandem System, Part Number 1165-4, in accordance with the requirements of Federal Aviation Regulation (FAR) Part 21, Subpart O, Technical Standard Order (TSO) C23b.

We find your Statement of Conformance, dated July 31, 1984, and your Quality Control Manual, dated July 1981, acceptable.

The following data, submitted with your July 31, 1984, letter will be retained on file for this authorization:

1. Statement of Conformance, dated July 31, 1984.
2. System Drawing for Hawk Tandem System, dated July 31, 1984.
3. Drop Test Summary Sheet, dated July 31, 1984.

Effective this date, you are authorized to identify the Strong Enterprises' Dual Hawk Tandem System, Part Number 1165-4, with the applicable TSO markings required by FAR 21.607(d).

This authorization is not transferable to another person or location and is effective until surrendered, withdrawn, or otherwise terminated by the Administrator.

Your responsibilities as a holder of a TSO authorization are outlined in FAR 21, Subpart O and FAR 21.3.

The TSO Specialist for your program is Jerry Boutwell, telephone (404) 763-7407.

Sincerely,

John R. James
Manager, Atlanta
Aircraft Certification Office



Edward Warren: First American Aloft

APPENDIX C: DHT Inspection Check List

Use this check-list to ensure all steps of the Inspection are completed.

Harness/Container SN _____ Date of Manufacture _____ In Service Date _____

				<i>Date of Inspection (Month/Year)</i>	Refer to Maintenance Inspection:
				Harnesses (Instructor and Student)	Page Section
				No rust on hardware	3-5 3.3.3.1
				Proper hardware installed.	3-5 3.3.3.1
				Springs on snaps still functional.	3-5 3.3.3.1
				4-point stitching on instructor side O-Ring attachments secure with no broken stitches.	3-5 3.3.3.1
				Hardware functional and tacked (leg strap Quick Ejectors).	3-5 3.3.3.1
				No cuts on webbing.	3-5 3.3.3.1
				Stitching is not unraveling on webbing.	3-5 3.3.3.1
				No excessive fading of webbing.	3-5 3.3.3.1
				Container	Page Section
				No rough edges, dents, or bends in grommets.	3-5 3.3.3.1
				Grommets secure and in place.	3-5 3.3.3.1
				Grommet fingernail test complete.	3-5 3.3.3.1
				Drogue riser "L" link screws tight.	3-5 3.3.3.1
				Closing pin housing on drogue riser securely tacked.	3-5 3.3.3.1
				No cuts or frays in drogue riser webbing.	3-5 3.3.3.1
				Closing flap and tuck tab stiffeners in good condition.	3-5 3.3.3.1
				No holes or tears in Cordura or binding.	3-5 3.3.3.1
				No broken stitches in Cordura or binding.	3-5 3.3.3.1
				Drogue pouch secure.	3-5 3.3.3.1
				No holes in drogue pouch.	3-5 3.3.3.1
				Opening securely holds Drogue.	3-5 3.3.3.1
				All Velcro© locations are clean.	3-5 3.3.3.1
				Velcro© is secure and in place.	3-5 3.3.3.1
				RipCORDS, Drogue Release Cables and Housings	Page Section
				No excessive wear of ripcord hardware.	3-5 3.3.3.2
				No kinks, frays, or broken strands in ripcord cables.	3-5 3.3.3.2
				Cable tip is not exposed.	3-5 3.3.3.2
				Reserve Pin straight.	3-5 3.3.3.2
				Swedge's are secure and approved parts.	3-5 3.3.3.2
				Red H.G. line on 3-ring release not frayed or cut.	3-5 3.3.3.2
				Rings on 3-ring release secure.	3-5 3.3.3.2
				No dents, cracks, or rough edges on rings.	3-5 3.3.3.2
				No prominent curves in 3-ring release cable.	3-5 3.3.3.2
				Housings complete, no broken or missing housing caps.	3-6 3.3.3.2
				Cable housings free of all dirt, gravel, sand, debris and are lubricated.	3-6 3.3.3.2

Main Canopy SN _____ Date of Manufacture _____ In Service Date _____

				<i>Date of Inspection (Month/Year)</i>	Refer to Maintenance Inspection:	
				Main Canopy	Page	Section
				Like line group deviation within 1-inch.	3-6	3.3.3.3
				No excessive wear in lines.	3-6	3.3.3.3
				No loose stitching at link, cascade, and canopy attachment bartacks.	3-6	3.3.3.3
				Rear riser cable housings secure.	3-6	3.3.3.3
				Rear riser cable housing clean and free of debris.	3-6	3.3.3.3
				No webbing wear at 3-ring attachment point.	3-6	3.3.3.3
				Stitching on riser webbing unbroken.	3-6	3.3.3.3
				Swedish link functional.	3-6	3.3.3.3
				No cracks in Rapide Links.	3-6	3.3.3.3
				No holes in slider, stitching good.	3-6	3.3.3.3
				No burrs on slider grommets.	3-6	3.3.3.3
				Slider grommets secure.	3-6	3.3.3.3
				Grommets on slider do not spin.	3-6	3.3.3.3
				Fingernail test on slider grommets complete.	3-6	3.3.3.3
				Seam and line attachment stitch intact.	3-6	3.3.3.3
				All panels free of damage.	3-6	3.3.3.3
				No holes, tears, or burns in the fabric.	3-6	3.3.3.3
				No excessive wear at bridle attachment point.	3-6	3.3.3.3

				Drogue and Deployment Bag	Page	Section
				No holes or tears in fabric.	3-7	3.3.3.4
				Reinforcing tape on drogue body undamaged.	3-7	3.3.3.4
				Stitching and zigzag at base of drogue canopy complete.	3-7	3.3.3.4
				Drogue mesh free of holes and tears.	3-7	3.3.3.4
				No loose or broken stitching in bridle.	3-7	3.3.3.4
				No holes or excessive wear in the bridle.	3-7	3.3.3.4
				Bridle attachment point not worn or frayed.	3-7	3.3.3.4
				Bumper and Rapide Link not damaged and in correct place.	3-7	3.3.3.4
				3-ring attachment complete and not bent or damaged.	3-7	3.3.3.4
				Y-deflation line bartack not loose or fraying.	3-7	3.3.3.4
				No excessive wear and no twists in the Y-deflation line.	3-7	3.3.3.4
				Drogue flex pin smooth, no nicks in coating, no broken strands in cable.	3-7	3.3.3.4
				Shock cord loops not broken or frayed, and not stretched out longer than 3 inches.	3-7	3.3.3.4
				Rubber bands in place and in good condition.	3-7	3.3.3.4
				Deployment bag grommets secure.	3-7	3.3.3.4
				Velcro secure and in good condition.	3-7	3.3.3.4



Photos of Tom Noonan and Dave Bazzoni

SET-366

www.strongparachutes.com

- The SET-366 is a high performance, semi-elliptical, 9 cell main canopy
- It provides soft, on heading openings combined with an increase in flight performance
- Toggle pressure has been dramatically reduced on the SET-366, making turns and flaring light and easy

You can spend all day long flying the SET-366 over and over again, and land your last jump of the day as smoothly as your first.

NEW Risers with Every Canopy!

SET-400

www.strongparachutes.com

- The most predictable and reliable tandem canopy available
- Durability leader in the tandem industry
- Consistent and dependable openings
- Smooth and responsive flight characteristics
- Exceptional penetration ability and flat glide

The SET-400 is a high performance, semi-elliptical 9-cell main canopy. Setting the bar for Tandem Flight since 1995.



Photos by Phil Roberson



Strong Enterprises

"The parachute company with imagination"

Division of S.E. Inc.

11236 Satellite Blvd. Orlando, FL 32837

Tel. (407) 859-9317 Fax: (407) 850-6978

www.strongparachutes.com sales@strongparachutes.com

PROUDLY MADE IN THE U.S.A